

TRACC[®]

Product Description Assembly Manual



TRINITY
HIGHWAY

Ahead of the Curve[®]

TRACC[®]

The TRACC[®] system has been tested pursuant to National Cooperative Highway Research Program (“NCHRP”) Report 350 specifications. The TRACC[®] system has been deemed eligible for federal-aid reimbursement on the National Highway System by the Federal Highway Administration (“FHWA”) as a TL-3 device.

Product Description Assembly Manual



2525 N. Stemmons Freeway
Dallas, Texas 75207



Important: These instructions are to be used only in conjunction with the assembly, maintenance, and repair of the TRACC[®] system. These instructions are for standard assembly specified by the appropriate highway authority. In the event the specified system assembly, maintenance, or repair would result in a deviation from these assembly instructions, contact the appropriate highway authority engineer. **Trinity Highway Products, LLC** (“Trinity Highway”) representatives are available for consultation if required.

This manual must be available to the worker overseeing and/or assembling the product at all times. For additional copies, contact Trinity Highway at (888) 323-6374 or visit www.trinityhighway.com.

The instructions contained in this manual supersede all previous information and manuals. The information, illustrations, and specifications in this manual are based on the latest TRACC[®] system information available to Trinity Highway at the time of printing. We reserve the right to make changes at any time. Please contact Trinity Highway to confirm that you are referring to the most current instructions.

Table of Contents

Customer Service Contacts	3
Important Introductory Notes	3
Safety Rules for Assembly	4
Safety Symbols	5
Limitations and Warnings.....	6
System Overview	8
How to Determine Left/Right.....	8
Defining the Bays	8
System Identification.....	9
Recommended Tools.....	10
Special Site Conditions	12
Other Factors to Consider.....	12
Location Requirements	13
Unidirectional Application.....	13
Bidirectional Application	14
Approach Zone and Clear Zone.....	14
Downstream Zone.....	14
Concrete Foundation Assembly	15
Foundation Assemblies.....	16
TRACC® Foundation Drawings Available Upon Request.....	16
Backup Frame and Transition Options.....	17
Nose Delineation Options	17
Assembly of System	18
Lifting the System.....	19
Anchoring the System.....	19
Attaching Backups and Transitions.....	20
System Maintenance.....	20
TRACC® Repair	21
Removal / Replacement of System.....	21
Types of Damage.....	21
System Repair Checklist.....	22
Attaching Backups and Transitions.....	23
Attaching Plastic Nose and Delineator.....	23

Customer Service Contacts

Trinity Highway is committed to the highest level of customer service. Feedback regarding the TRACC[®] system, its assembly procedures, supporting documentation, and performance is always welcome. Additional information can be obtained from the contact information below:

Trinity Highway

Telephone:	(888) 323-6374 (USA) +1 214 589 8140 (International)
E-mail:	product.info@trin.net
Website:	www.trinityhighway.com

Important Introductory Notes

Proper assembly of the TRACC[®] system is critical to achieve performance that has been evaluated and deemed eligible for reimbursement by the FHWA per NCHRP Report 350. These instructions should be read in their entirety and understood before assembling TRACC[®] system. These instructions are to be used only in conjunction with the assembly of TRACC[®] system and are for standard assemblies only as specified by the applicable highway authority. If you need additional information, or have questions about the TRACC[®] system, please contact the highway authority that has planned and specified this assembly and, if needed, contact Trinity Highway Customer Service Department. This product must be assembled in the location specified by the appropriate highway authority. If there are deviations, alterations, or departures from the assembly instructions specified in this manual, the device may not perform as it was tested.



Important: DO NOT use any component part that has not been specifically approved for this system during assembly or repair.

This product has been specified for use by the appropriate highway authority and has been provided to that user who has unique knowledge of how this system is to be assembled. No person should be permitted to assemble, maintain, or repair this system that does not possess the unique knowledge described above. These instructions are intended for an individual qualified to both read and accurately interpret them as written. These instructions are intended only for an individual experienced and skilled in the assembly of highway products that are specified and selected by the highway authority.

A manufacturer's drawing package will be supplied by Trinity Highway upon request. Such drawings take precedence over information in this manual and shall be studied thoroughly by a qualified individual who is skilled in interpreting them before the start of any product assembly.



Important: Read safety instructions thoroughly and follow the assembly directions and suggested safe practices before assembling, maintaining, or repairing the TRACC[®] system. Failure to follow this warning can result in serious injury or death to workers and/or bystanders. Please keep up-to-date instructions for later use and reference by anyone involved in the assembly of the product.



Warning: Ensure that all of the TRACC[®] system Danger, Warning, Caution, and Important statements within the TRACC[®] manual are completely followed. Failure to follow this warning could result in serious injury or death in the event of a collision.

Safety Rules for Assembly

*** Important Safety Instructions ***

This manual must be kept in a location where it is readily available to persons who are skilled and experienced in the assembly, maintenance, or repair of the TRACC[®] system. Additional copies of this manual are available from Trinity Highway by calling (888) 323-6374, by email at product.info@trin.net or at www.trinityhighway.com. Please contact Trinity Highway if you have any questions concerning the information in this manual or about the TRACC[®] system.









Always use appropriate safety precautions when operating power equipment, mixing chemicals, and when moving heavy equipment or TRACC[®] system components. Gloves, apron, eye protection, safety toe shoes, and back support are recommended when appropriate.



Warning: Safety measures incorporating traffic control devices specified by the highway authority must be used to provide safety for personnel while at the assembly, maintenance, or repair site.

Safety Symbols

This section describes the safety symbols that appear in this TRACC[®] system manual. Read the manual for complete safety, assembly, operating, maintenance, repair, and service information.

<u>Symbol</u>	<u>Meaning</u>
	Safety Alert Symbol: Indicates Danger, Warning, or Caution. Failure to read and follow the Danger, Warning, Caution, or Important indicators could result in serious injury or death to the workers and/or bystanders.
	Warning: Failure to comply with these warnings could result in increased risk of serious injury or death in the event of a vehicle impact with a system that has not been accepted by the FHWA.
	Warning: Do not assemble, maintain, or repair the TRACC [®] system until you have read this manual thoroughly and completely understand it. Ensure that all Danger, Warning, Caution, and Important statements within the manual are completely followed. Please call your Trinity Highway representative if you do not understand these instructions.
	Warning: Safety measures incorporating appropriate traffic control devices specified by the highway authority must be used to protect all personnel while at the assembly, maintenance, or repair site. Failure to follow this warning could result in serious injury or death in the event of a collision. The traffic control plan established by the highway authority must always be observed in assembling or utilizing this product.
	Warning: Do NOT modify the TRACC [®] system in any way.
	Warning: Ensure that the TRACC [®] system and delineation used meet all federal, state, specifying agency, Manual on Uniform Traffic Control Devices ("MUTCD"), and local specifications.
	Warning: Ensure that your assembly procedure meets all appropriate Occupational Safety and Health Administration (OSHA) and local standards.
	Warning: Ensure that this assembly conforms with the guidance provided by the AASHTO Roadside Design Guide, including, but not limited to, those regarding placement on or adjacent to curbs.

Limitations and Warnings

Trinity Highway contracts with FHWA approved testing facilities to perform crash tests, evaluation of tests, and submittal of results to the FHWA for review.

The TRACC[®] system has been deemed eligible for reimbursement by FHWA as meeting the requirements and guidelines of NCHRP Report 350.

TABLE 1	Test Level	Width	Length
TRACC[®]	3	24", 30" Uni	21'
ShorTRACC[™]	2	24", 30" Uni	14'
FasTRACC[™]	3+ *	24", 30" Uni	25' – 8"
WideShorTRACC[™] - L	2	31", 39"	14' – 1"
WideShorTRACC[™] - R	2	31", 39"	14' – 1"
WideShorTRACC[™] - B	2	31", 39"	14' – 1"
WideTRACC[™] - L	3, 3+ *	31" – 42" **	21' **
WideTRACC[™] - R	3, 3+ *	31" – 42" **	21' **
WideTRACC[™] - B*	3, 3+ *	39" - 58" **	21' ***
WideFasTRACC[™] - L	3, 3+ *	39" – 71" **	25' – 11" **
WideFasTRACC[™] - R	3, 3+ *	39" – 71" **	25' – 11" **
WideFasTRACC[™] - B	3, 3+ *	39" – 71" **	25' – 11" **

*-Test Level 3+ refers to the fact that some units have been tested or are accepted for test conditions that exceed normal Test Level 3. Additional testing included a 2000 kg [4410 lb] vehicle impacting at zero degrees at 70 MPH [110 km/h].

** - The width of the WideTRACC[™]-L and –R can be increased by adding approved wing extensions on one side. The extensions will add 28" [711 mm] of length and 3-7/16" [164 mm] of width for each section.

*** - The width of the WideTRACC[™]-B can be increased by adding approved wing extensions on both sides. The extensions will add 28" [711 mm] of length and 6-7/8" [175 mm] of width for each section.

Trinity Highway expressly disclaims any warranty or liability for injury or damage to persons or property resulting from any impact, collision or harmful contact with products, other vehicles, or nearby hazards or objects by any vehicle, object or person, whether or not the products were assembled in consultation with Trinity Highway or by third parties.

The TRACC[®] system was designed to be assembled at a specific deployment site, delineated, and maintained in accordance with local guidelines. Standard yellow reflective sheeting is provided with each TRACC[®] system and can be used to delineate left shoulder, right shoulder, and gore applications. The plastic Nose should be attached to the front of the TRACC[®] system using the Fender Panel attachment hardware located on the system.

Note: Consult local transportation authorities for delineation requirements.

The highway authority engineer, or other specifying authority, should be careful to properly select, assemble, and maintain the product. Careful evaluation of site placement, vehicle population type, speed, traffic direction, and visibility are some of the elements that require evaluation in the proper selection of a safety appurtenance. Review the Special Site Conditions section on page 12.

WideTRACC[™] offers options in shielding wide barriers and gores. The WideTRACC[™] can be flared down its left side only, its right side only, or both sides simultaneously. The extension attached to the rear of the WideTRACC[™] consists of a pair of guardrail panels continuing the height and flare angle of the WideTRACC[™] Fender Panels. The lower Fender Panel is further supported by a channel that is attached between the post and the guardrail.

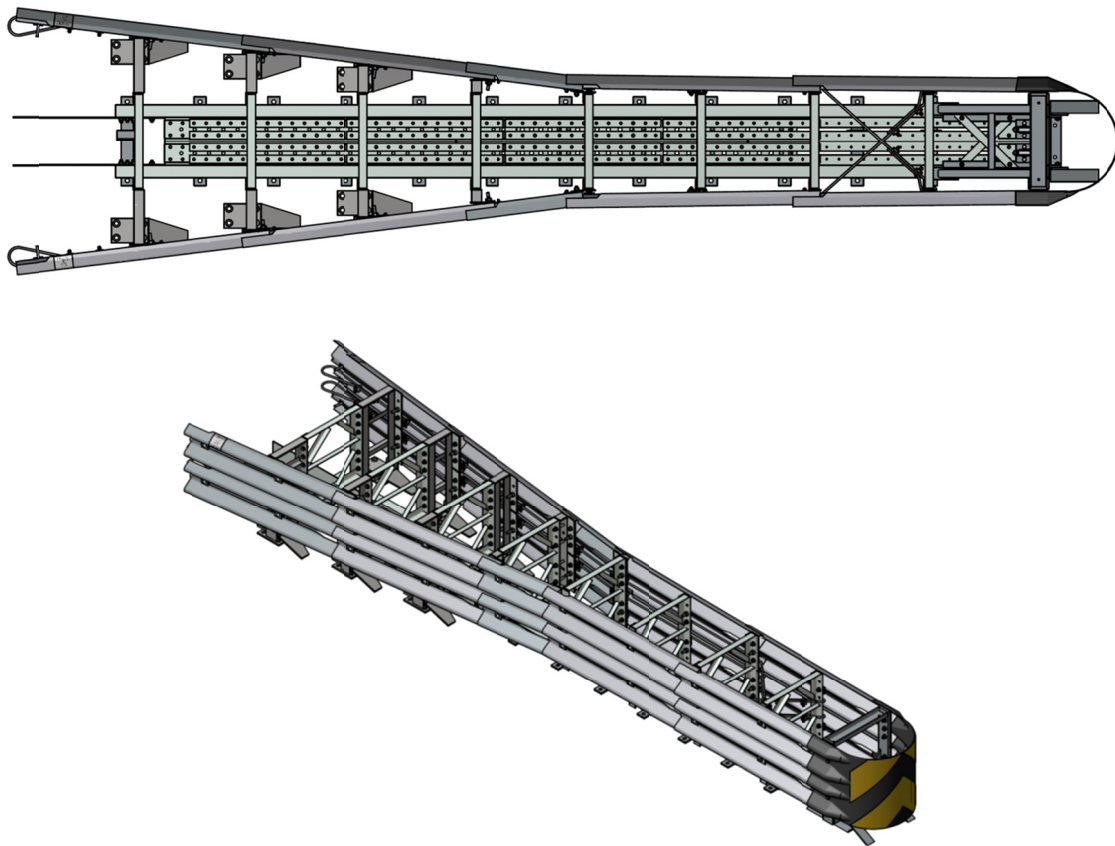

Figure 1 – WideTRACC[™]-B (Both Sides Flared)



Important: The WideTRACC[™] is shipped from the plant with the cables connected behind the last frame. Ensure cables are unbolted, wrapped, and secured around the split frame backup/base plated post.

System Overview

The TRACC[®] system is a potentially reusable, re-directive crash cushion for roadside features up to 1800 mm [71"] width or even wider with use of wing extensions. The Steel Backup Frame of the parallel TRACC[®] system is designed to be placed against a fixed object. Whether the system is reusable after an impact is left to the sound discretion of the highway authority specifying the use of the system.

How to Determine Left/Right

To determine left from right when ordering transitions, stand in front of the system facing the roadside feature. Your left is the system's left and your right is the system's right.

Defining the Bays

The plastic Nose is located in front of the Sled Bay. The first two Bays consist of one Sled, two Frames, and four Fender Panels.

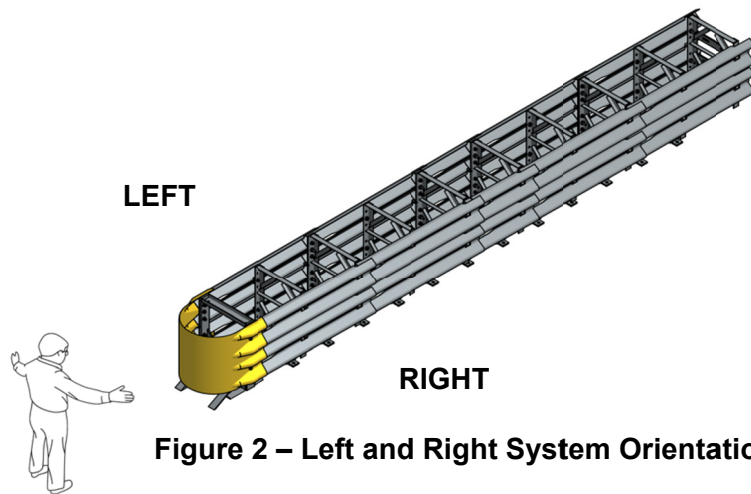

Figure 2 – Left and Right System Orientation

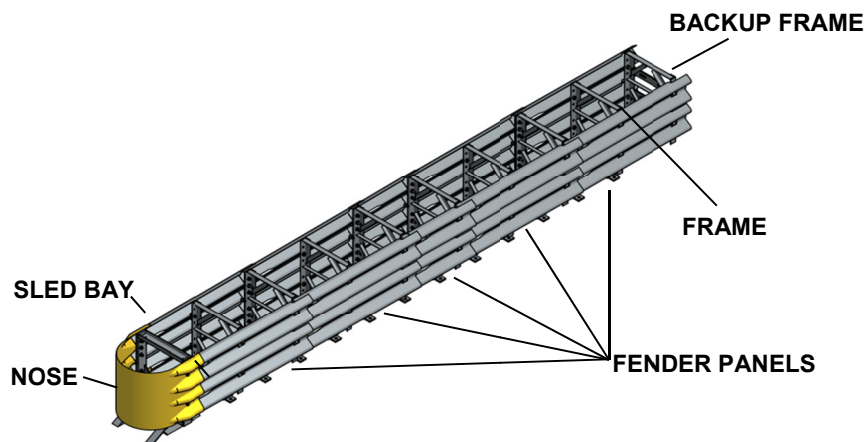
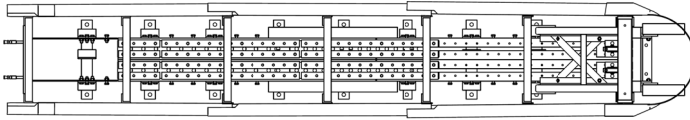
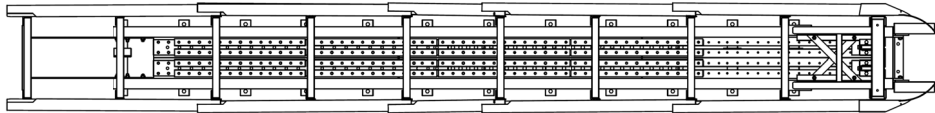

Figure 3 – TRACC[®] System

System Identification



[24" or 30"] Wide [14'] Long – ShorTRACC™ – TL-2



[24" or 30"] Wide [21'] Long - TRACC® – TL-3

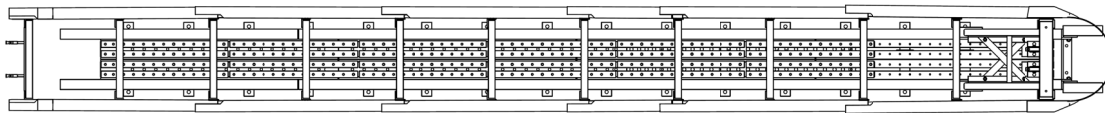

[24" or 30"] Wide [25' 8"] Long – FastrACC™ – TL-3+

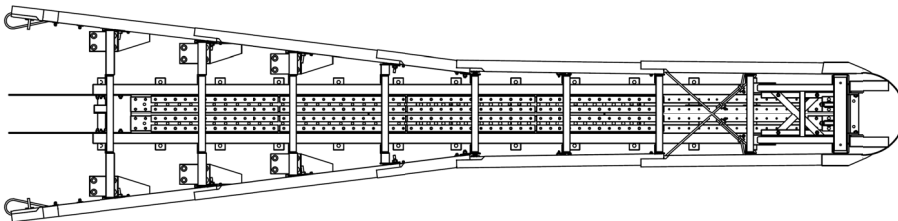

[41" L or R Flared] [58" Both Sides Flared] Wide [21'] Long – WideTRACC™ – TL-3

Figure 4 – TRACC® Configurations

Recommended Tools

Documentation

- Manufacturer's Assembly Manual
- Manufacturer's Drawing Package

Personal Protective equipment

- Eye Protection
- Gloves
- Back Support for Lifting
- Safety Toe Shoes

Cutting equipment

- Rebar cutting bit 18 mm [11/16"]
- Concrete drill bits – 18 x 400 mm [11/16" x 16"] with 750 mm [30"] extender (Double-Fluted)
- Rotary Hammer Drill



Important: Use only double-fluted drill bits with Trinity Highway approved adhesive to achieve optimum tensile strength. Do not use diamond drill bits for anchors as the surface will be too smooth for adhesive.

Hammers

- Sledge Hammer

Wrenches

- Heavy duty impact wrench 13 mm [1/2"] drive
- Standard adjustable wrench 305 mm [12"]
- Socket and Ratchet Set or Flat Wrenches – 10 mm to 32 mm [3/8" to 1 1/4"]
- Ratchet and attachments for the above sockets
- 13 mm [1/2"] drive breaker bar – 610 mm [24"] long
- 2 ea. Open/Box End Wrench – 19 mm [3/4"]
- 2 ea. Open/Box End Wrench – 27 mm [1 1/16"]
- 2 ea. Open/Box End Wrench – 32 mm [1 1/4"]



Important: The TRACC[®] system is assembled using Imperial hardware. Trinity Highway recommends using Imperial tools when assembling or servicing the TRACC[®] system.



Important: All Metric tool sizes are for reference only.

Miscellaneous

- Traffic control equipment
- Lifting and moving equipment (A lifting device is preferred although a forklift can be used.) A minimum of 2,000 kg [4,400 lb] capacity is required.
- Lifting slings or chains
- Air compressor 690 kPa (100 psi minimum) and generator (5 kW)
- Long pry bar
- Drift pin 305 mm [12"]
- Center punch
- Tape measure 7.6 m [25']
- Chalk line
- Concrete marking pencil
- Rags, water, and solvent for touch-up
- Dispensing gun and mixing tubes for HILTI HY-200 Adhesive

Note: HILTI anchors supplied with TRACC® systems require 18 mm [11/16"] diameter holes for assembly. Dispensing gun and mixing tubes for HY-200 adhesive are available from Trinity Highway or directly from HILTI, Inc.

Note: The above list of tools is a general recommendation and should not be considered an extensive list. Depending on specific site conditions and the complexity of the assembly specified by the appropriate highway authority the required tools may vary. Decisions as to what tools are needed to perform the job are entirely within the discretion of the specifying highway authority and the authority's selected contractor performing the assembly of the system at the authority's specified assembly site.

Special Site Conditions

Contact Trinity Highway Customer Service Department if you would like assistance with a special application (p. 3). You will need to be able to answer the following TRACC[®] system questions:

1. **Are curbs present at the site? What height are they?** All curbs over 101 mm [4"] high should be removed. If possible, curbs less than 101 mm [4"] high should be removed approximately 15 m [50'] in front of the TRACC[®] system and as far back as the system's Backup Frame (p. 8). Any curbs that **must** remain can be a maximum height of 101 mm [4"] or lower and be mountable.
2. **Is there a cross-slope of more than 8% (5 degrees)?** If so, a leveling pad **must** be used.
3. If the assembly site is a gore area (place where two roads diverge), **what is the angle of divergence?**
4. **What is the general geometry of the site?** Please include the roadway for 150 m [500'] in front of proposed area so traffic patterns can be visualized.
5. **Is there is an existing guardrail or median barrier at the site?** If so, the Backup of the TRACC[®] system should tie into the existing guardrail or median barrier.
6. **Will there be traffic approaching from the rear of the system? Is the system in a bi-directional traffic situation, with traffic going in opposite directions on either side of the system? Will the system be on the side of the road in a location where crossover traffic is a concern?** If so, a transition from the back of the system to the fixed object is necessary to prevent vehicle snagging. See page 13 for the Bidirectional Application section.
7. **Do the foundation requirements meet or exceed the system footing specification in this manual?** See page 15 for the Foundation Assemblies section.
8. **Are there any other unique features at the site that may affect positioning or performance of the TRACC[®] system?** See page 14 for Bidirectional Traffic illustration.



Warning: Ensure that there is proper site grading for the TRACC[®] system placement as dictated by the state or specifying agency, pursuant to FHWA acceptance.

Other Factors to Consider

1. The existence of drain inlets.
2. Junction boxes or other items located near the roadside feature.
3. Insufficient space for the system length.
4. The location and movement of expansion joints.

Location Requirements

Unidirectional Application

Assembly of a TRACC® system and its backup connections or transitions depends on the traffic pattern and the road feature at the particular location. Unidirectional traffic (one side or both) requires no transition (Figures 5 and 6), only a connection to a backup structure. The Backup Frame can be attached to any solid structure including a square cast-in-place concrete pillar, a vertical concrete wall, or the end of a New Jersey-style barrier with additional brackets (p. 8). For “free-standing” assemblies, Trinity Highway can provide two (2) standard guardrail posts to be driven or two (2) foot-plate posts to be anchored to the concrete or asphalt pad and attached to the Backup Frame. Trinity Highway can provide an adaptor to allow direct attachment of the Backup Frame to a variety of concrete barrier or guardrail profiles. Call Customer Service at 1-888-323-6374 or your local Trinity Highway representative with questions regarding this and other types of assembly.

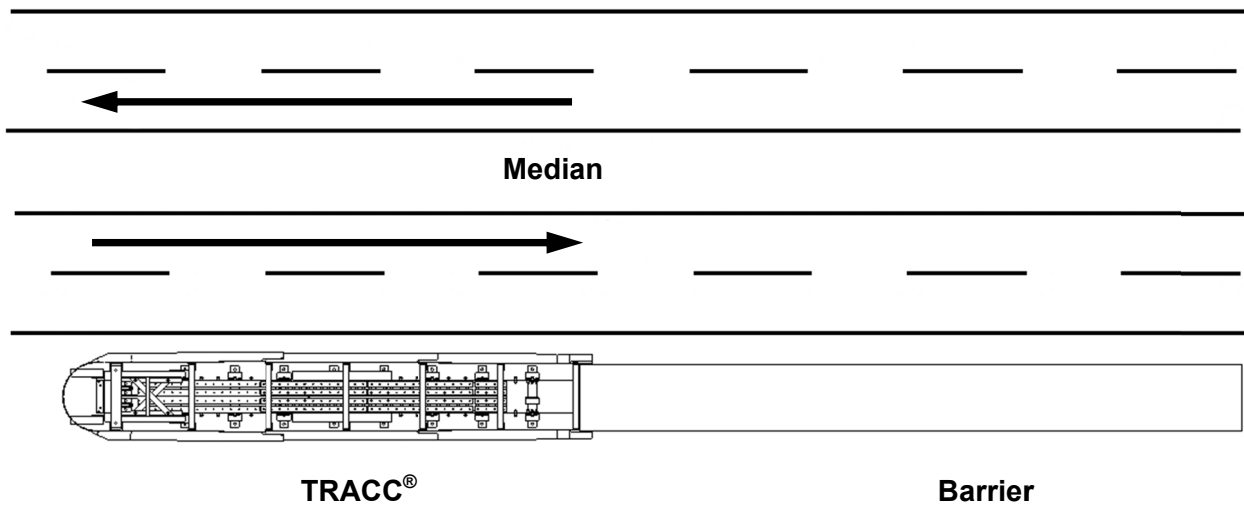

Figure 5 - Unidirectional Traffic Flow – One Side – Requires No Transition

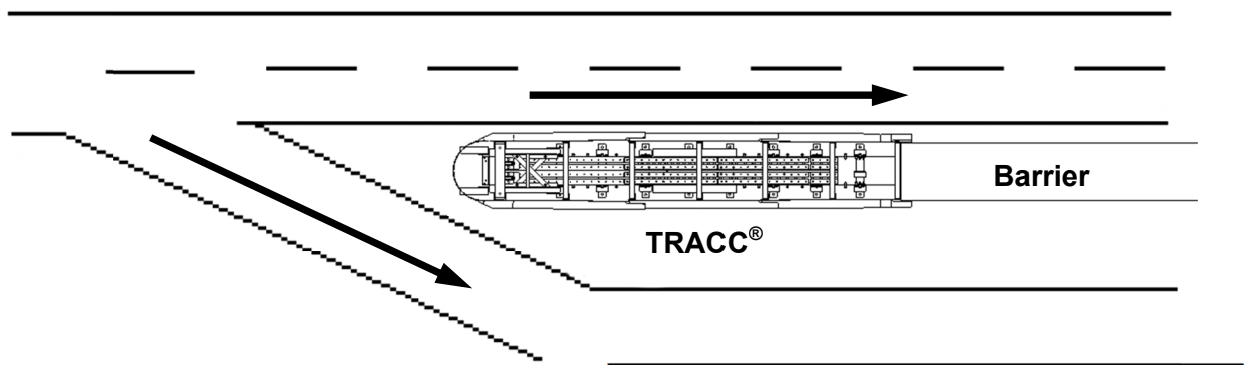

Figure 6 - Unidirectional Traffic Flow – Both Sides – Requires No Transition

Bidirectional Application

See Figure 7 for assemblies that face oncoming traffic from the reverse direction. Appropriate transitions must be applied to the end of the backup structure. Trinity Highway can provide transitions for a variety of concrete barrier or guardrail profiles.

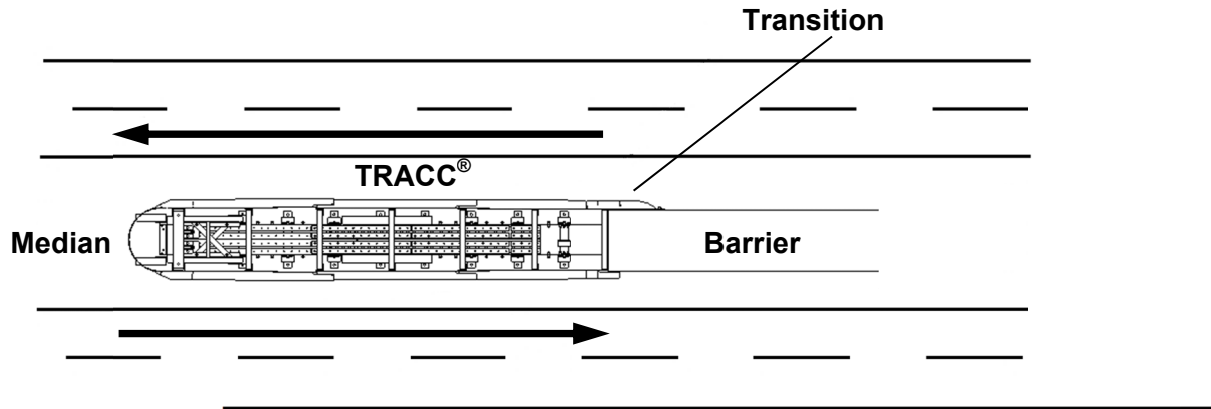

Figure 7 - Bidirectional Traffic Flow – Requires Transition on One Side.

Approach Zone and Clear Zone

The AASHTO Roadside Design Guide states the TRACC® should not be placed directly behind a raised curb. The approach area in front of the system in the direction of traffic flow should slope at a rate of no greater than 10% (6 degrees or 10:1) from the surrounding area. The cross-slope should differ from the surrounding area by no more than 8% (5 degrees or 12:1). The clear zone behind the TRACC® should be consistent with the area behind the downstream Length-of-Need (“LON”) of the barrier. The entire length of the TRACC® can be used in LON calculations as it is fully redirecting.

Downstream Zone

The TRACC® system should be assembled so that a 1524 mm [60"] clear space will exist on both sides of the road feature for the Fender Panels to retract during an end-on impact (Figure 8).

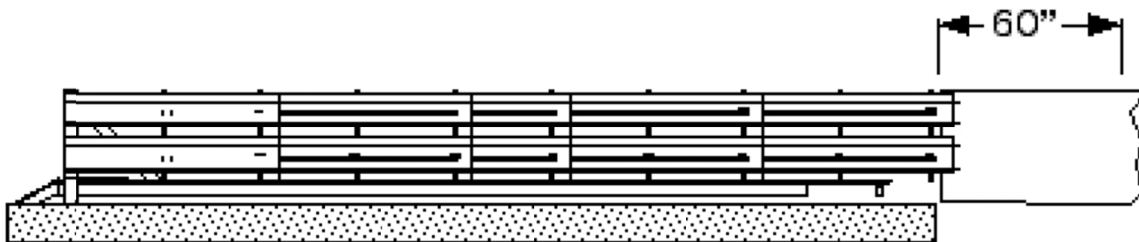

Figure 8 - Clear Space for Panel Retraction

Site Preparation/Foundation

Concrete Foundation Assembly

For concrete installations, the TRACC[®] system should be installed only on an existing or freshly placed and cured concrete base (28 MPa [4000 psi] minimum). Use 191 mm [7-1/2"] threaded rods attached with appropriate anchor material. Orientation of the concrete base and the attenuator must comply with the project plans or as otherwise determined by the resident project engineer or appropriate highway authority.

Recommended dimension and reinforcement specifications for new concrete foundations are provided in Trinity Highway concrete foundation drawings and are available upon request (p.15). The system may be assembled on an un-reinforced concrete roadway (minimum 203 mm [8"] thick).



Caution: Accurate placement of all steel rebar is critical to avoid interference with the concrete anchor bolts.



Warning: Location of the Backup Frame in relation to the roadside feature and nearby objects will affect the operation of the attenuator (p. 18). Upon impact, the Fender Panels telescope rearward and extend beyond the rigid Backup Frame and fixed object as much as 1.00 m [3-1/3'] from their pre-impact location; therefore, all Panels must be able slide back and past concrete walls, barriers, or pillars. Failure to comply with this requirement may result in untested system performance.

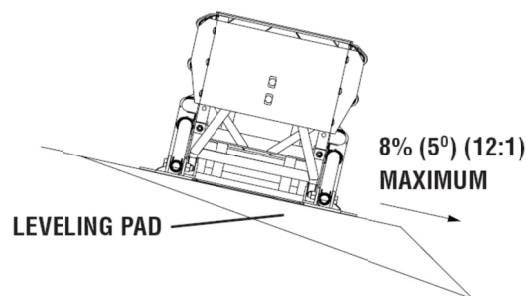

Figure 9 - Cross-Slope

Cross-Slope

Assembled cross-slope shall not exceed 8% (5 degrees) and not vary (twist) more than 2% (1 degree) over the length of the system (Figure 9). The foundation surface should have a light broom finish.

Asphalt Foundation Assembly

The TRACC[®] system may be installed on asphalt in construction zones. A minimum of 76 mm [3"] layer of asphalt over a minimum of 76 mm [3"] layer of Portland Cement concrete, 152 mm [6"] layer of asphalt over 152 mm [6"] layer of subbase, or 203 mm [8"] layer of asphalt with no subbase or 457 mm [18"] threaded rods, installed with appropriate anchoring material for these foundations.

Foundation Assemblies

During an impact within the NCHRP Report 350 criteria, the stopping force provided by a TRACC[®] system is **NOT** transferred to the backup structure beyond the cushion. All stopping loads pass through the system anchor bolts directly to the foundation.

TRACC[®] systems can be mounted to combinations of asphalt, concrete, and compacted subbase as shown in Table 2 below.

Table 2 - Foundation Options

6"	Reinforced Concrete
8"	Unreinforced Concrete
3"	Asphalt over 3" Minimum Concrete
6"	Asphalt over 6" Compact Sub Base
8"	Minimum Asphalt

TRACC[®] Foundation Drawings Available Upon Request

SS1010	TRACC [®] TL-3 Crash Cushion Attenuating Terminal 22' Concrete Foundation Plan
SS1011	FasTRACC [®] TL-3 Crash Cushion Attenuating Terminal 26' 3" Concrete Foundation Plan
SS1013	ShorTRACC [®] TL-2 Crash Cushion Attenuating Terminal 15' Concrete Foundation Plan

Backup Frame and Transition Options

The TRACC[®], with its sliding Fender Panels, can be attached or transitioned to an appropriate road feature capable of supporting the Backup Frame (p. 18). For “free-standing” assemblies, Trinity Highway can provide two (2) standard guardrail posts to be driven or two (2) foot-plate posts to be anchored to the concrete or asphalt pad and attached to the Backup Frame (p. 18). Trinity Highway can provide backup connections or transitions for a variety of concrete barrier or guardrail profiles.

The following drawings are located in the back of this manual. Each drawing provides the necessary detail for attachment and transition.

SS453 – TRACC[®] Transition to W-Beam Median Barrier Soil Post Option

SS454 – TRACC[®] Transition to Thrie Beam Median Barrier Soil Post Option

SS455 – TRACC[®] Transition W-Beam Median Barrier Plan, Elevation & Sections

SS456 – TRACC[®] Transition to Vertical Wall

SS461 – TRACC[®] Transition to Concrete Safety Shape Barrier Plan, Elevation & Sections

SS462 – TRACC[®] Transition to Concrete Barrier Single Slope Plan, Elevation & Sections

SS463 – TRACC[®] Transition to Thrie Beam Median Barrier Plan, Elevation & Sections

SS464 – TRACC[®] Transition to Thrie Beam Median Barrier All Wood Post

SS497 – WideTRACC[™] – Optional Wing Extensions

SS1001 – TRACC[®] Base Unit

SS1004 – SHORTRACC Base Unit

SS1007 – FASTRACC Base Unit

SS1045 – WideFasTRACC[™] - Double Flare



Important: Ensure you have the latest drawings from Trinity Highway for appropriate application.

Nose Delineation Options

The TRACC[®] is intended for use on either shoulder or median in both unidirectional and bidirectional traffic situations. Delineation of the plastic Nose section can be customized for any location. Standard yellow reflective sheeting is provided with the TRACC[®] and can be used to delineate left shoulder, right shoulder, or gore applications.

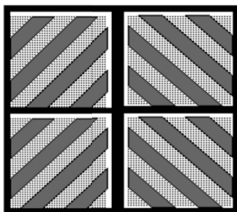

Gore Area

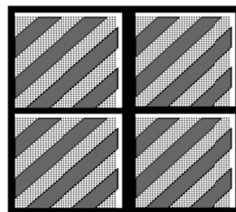

Right Shoulder

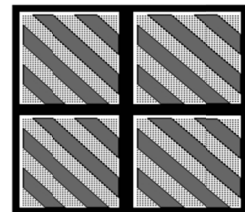

Left Shoulder

Figure 10 – Nose Delineation Options

Note: Consult local transportation authorities for delineation requirements.

Assembly of System

To facilitate accurate communication regarding the parts of the TRACC[®], Figure 11 shows the system with Fender Panels and Rip Plates removed.

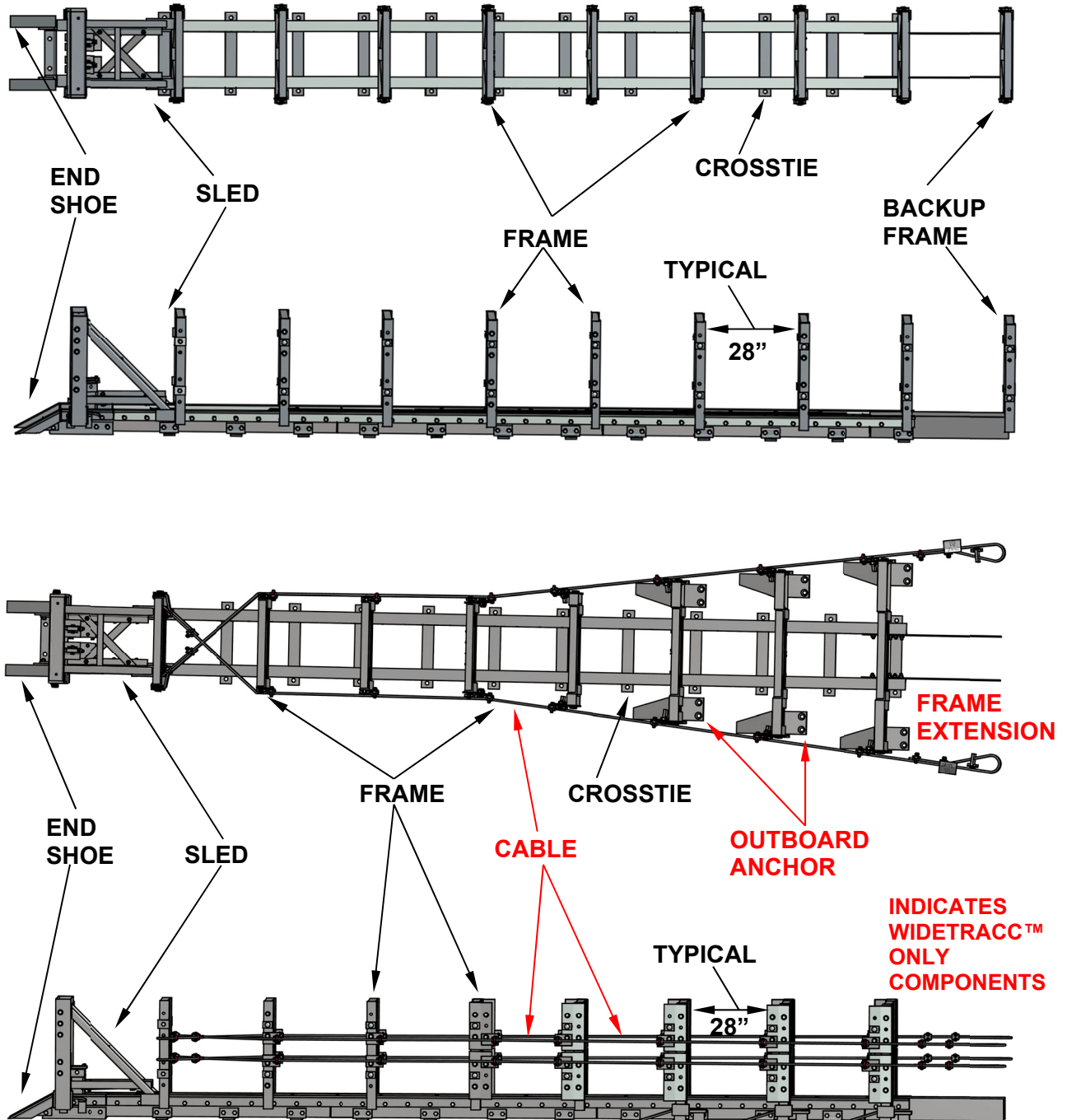

Figure 11 - Major Components of the TRACC[®]

Note: Fender Panels have been removed from the outside of the system for clarity.

Lifting the System

TRACC[®] systems can be lifted as complete units by threading lifting chains or slings directly through the tops of the Frames. Care should be taken to ensure that the system can be handled safely prior to and during any move.

Anchoring the System

TRACC[®] systems can be placed on combinations of asphalt and concrete. Table 3 shows the types of foundations that can be used and the anchoring studs that are required. In general, systems assembled on concrete are attached using 5/8" x 7-1/2" anchor studs while asphalt assemblies require 18" anchor studs. Holes should be drilled 1-1/2" less than the overall length of the anchor stud to ensure proper embedment.

TABLE 3 – Anchor Stud Selection Table

Foundation	Anchor Stud Size
6" Reinforced	5/8" x 7 – 1/2"
8" Unreinforced Concrete	5/8" x 7 – 1/2"
3" Min. Asphalt over 3" Min. Concrete	5/8" x 18"
6" Asphalt over 6" Compact Subbase	5/8" x 18"
8" Min. Asphalt	5/8" x 18"



Important: If asphalt is located over a minimum of 6" of concrete, the 18" anchor studs can be cut off to a total length equal to the asphalt thickness plus 7-1/2".

TRACC[®] systems can be placed directly onto the foundation as a complete unit. The system should be aligned within 1° of the downstream barrier according to the approach and downstream zone requirements set forth in the section entitled, Location Requirements (p. 13). Holes for the anchor studs can be drilled into foundation using the system as a template. Because of the open design of all the TRACC[®] systems, including the WideTRACC[™], it is not necessary to disassemble any portion of the system in order to drill the anchoring holes. Note that the flared portion of the WideTRACC[™] requires additional outboard anchors that have been shipped loose and must also be anchored to the foundation. Consult drawing, (SS1045) WideTRACC[™] Double Flare – Plan Elevations and Sections, for location of outboard anchors.

After the holes are drilled, brushed, and air blown (per adhesive manufacturer's instructions) the adhesive system can be dispensed into the hole and then the anchor stud should be suspended by its nut and washer through the crosstie. Figure 12 shows how the anchor stud should pass through the crosstie suspended by its nut and washer. The stud should hang in the uncured adhesive with no threads showing above the nut. Final tightening of the anchor nuts should be done after the adhesive has set.



Important: See adhesive manufacturer's instructions for set times under various environmental conditions.

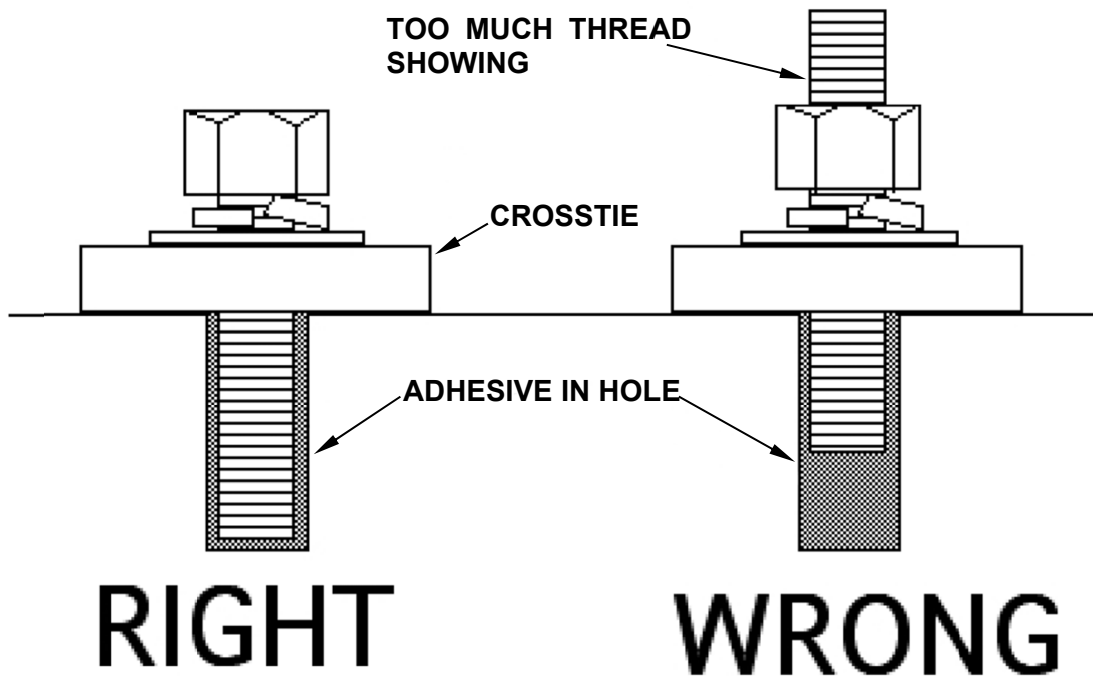

Figure 12 – Suspending the Anchor Studs in the Uncured Adhesive

Attaching Backups and Transitions

The Backup Frame on a TRACC[®] system must be attached to an appropriate road feature in order to support the Fender Panels and any required Transition Panel(s). While no direct stopping forces are transferred to the backup support structure, its presence is important for possible redirect impacts. Drawings in the back of this manual show the TRACC[®] systems attached to and shielding a variety of downstream barriers and structures. For more information about specific assembly options not shown in drawings contact Trinity Highway Customer Service (p. 3).



Important: The width of the WideTRACC[™] can be adjusted through the addition of wing extension sections as shown in drawing SS497, WideTRACC[™] Double Flare Wing Extension Structures, located in the back of this manual.



Important: The WideTRACC[™] is shipped from the plant with the cables connected behind the last frame. Ensure cables are unbolted, wrapped, and secured around the split frame backup/base plated post.

System Maintenance

The TRACC[®] system is a low maintenance roadside safety feature. Except for repairs due to impact, there may be no maintenance required for the system. That decision is left to the highway authority specifying this system. It is recommended that an annual drive-by inspection be performed to ensure that no minor impacts went undetected and that debris has not accumulated around the system.

TRACC[®] Repair

TRACC[®] systems are designed for field repair or rapid replacement of the entire unit.



Important: Because every impact is different, Trinity Highway makes no recommendation whether use or reuse of any part of the system is appropriate or acceptable following an impact. It is the sole responsibility of the local authority and its engineers to make that determination. It is critical that you inspect this product after assembly is complete to make certain that the instructions provided in this manual have been strictly followed.

The energy-absorbing Rip Plates of the base assembly of the TRACC[®] system can be replaced in stages depending on the extent of the impact. Because TRACC[®] systems are delivered fully assembled, replacing the entire damaged system on the roadside and then performing the necessary repairs safely and accurately in the maintenance shop away from traffic dangers may be more practical.

Removal / Replacement of System

The TRACC[®] system can be removed from its foundation by releasing the Anchor Nuts that hold down the Crossties. Flat wrenches may be required to access the Anchor Studs under the displaced Frames and Sled. Once released, the system can be lifted as a unit and transported back to a maintenance facility for repair. A new or reconditioned TRACC[®] system can be positioned on the existing Anchor Studs and firmly attached using approved nuts and washers.

In some impacts, a small number of Anchor Studs may become bent or fractured. In these cases it will be necessary to remove the old Anchor Stud, drill out the adhesive in the old hole, and replace the removed Anchor Stud with a new Anchor Stud and adhesive.



Important: TRACC[®] products are **NOT** disposable. Complete replacement of a roadside system after an impact is a convenient, but not required, way to protect workers by limiting exposure to traffic. Much of a TRACC[®] system may be reusable after design impacts regardless of whether the repair is performed in the field or in the maintenance yard. All decisions for reusability are made by the specifying highway authority.

Types of Damage

TRACC[®] systems are designed to withstand end-on impacts and redirecting side impacts within the NCHRP Report 350 criteria. Side impacts, depending on the severity, may only cause cosmetic damage to the system. Any system that has been impacted along its side should be examined to ensure that the damage is only cosmetic and that any damage that might hinder subsequent functions of the system is repaired. During some severe high-speed redirecting impacts with heavy vehicles, a TRACC[®] system may become permanently twisted. If the deformation of the Base Assembly causes a portion of one side of the system to be raised more than 1 1/2" when compared to the other side of the system, then the damaged portion of the Base Assembly should be replaced.

System Repair Checklist

- Replacing the TRACC[®] Rip Plates is a two person job.
- Remove the Plastic Nose by removing the four bolts.
- Remove the first set of Fender Panels (4) (upper and lower) closest to the front of the collapsed system by removing bolts (4 bolts at upper Panel & 3 bolts at lower Panel on each side).
- Remove both pins holding Shredder Bolts in place in the Sled Assembly.
- Loosen and remove one rear bolt at each of the diagonally crossed flat bars located on the Sled Assembly.
- Swing each flat bar parallel to the side of the Sled Assembly, and the front bolts can be loosened slightly to allow the two bars to rotate outward.
- Slide the Sled Assembly all the way forward.
- Loosen and remove Doubler Plate bolts from the TRACC (3 bolts at each Doubler Plate).
- Remove all Doubler Plates at damaged Rip Plate locations.
- Remove exposed and damaged Rip Plates.
- Remove Shredder Bolts that may be wedged within damaged Rip Plates as the Shredder Bolts may need to be tapped loose with a hammer.
- Ensure correct replacement and sequence of Rip Plates by checking all part numbers and referring to appropriate Trinity drawings (p. 33 – 35).
- Insert new Rip Plates starting from the back.
- Re-attach the Doubler Plates on top of the Rip Plates.
- Tighten the whole assembly down with bolts (3 bolts at each Doubler Plate).
- Attach Rip Plate Shredder Bolts and crossed flat bars to the front assembly sled.
- Slide all Frames forward to equidistant positions behind the Sled Assembly.
- Ensure Fender Panels are not wedged or caught on any portion of the system when sliding Frames forward with or without Fender Panels attached.
- Once Frames are in place, re-attach remaining Fender Panels.
- Reattach / replace the Plastic Nose.
- Verify all bolts are in place and tight.

Attaching Backups and Transitions

The Backup Frame on a TRACC[®] system must be attached to an appropriate backup structure in order to support the Fender Panels and any required Transition Panel(s). While no direct stopping forces are transmitted into the backup support structure if hit within the NCHRP Report 350 criteria, its presence is important for possible redirecting impacts. For “free-standing” assemblies, Trinity Highway can provide two (2) standard guardrail posts to be driven or two (2) foot-plate posts to be anchored to the concrete or asphalt pad and attached to the Backup Frame. For more information about specific assembly options, including reference drawings, contact your Trinity Highway representative (p. 3).



Important: The WideTRACC™ comes with cables attached to the last frame. Take cable clamps off to wrap cables around backup and secure both cables with clamps.

Attaching Plastic Nose and Delineator

The TRACC[®] system is intended for use on a roadway shoulder or median in both unidirectional and bidirectional traffic situations. Delineation of the plastic Nose section can be customized for any particular location. Standard yellow reflective sheeting is provided with each TRACC[®] system and can be used to delineate left shoulder, right shoulder, and gore applications. The plastic Nose should be attached to the front of the TRACC[®] system using the Fender Panel attachment hardware located on the system.



Important: Consult local transportation authorities for delineation requirements.



Warning: Use only Trinity Highway parts that are specified herein for the TRACC[®] for assembling, maintaining, or repairing the TRACC[®] system. **Do not utilize or otherwise comingle parts from other systems** even if those systems are other Trinity Highway systems. Such configurations have not been tested, nor have they been accepted for use. Assembly, maintenance, or repairs using unspecified parts or accessories is strictly prohibited. Failure to follow this warning could result in serious injury or death in the event of a vehicle impact with an UNACCEPTED system.

POST NO.	QTY	DESCRIPTION
1000	2	10'x17' TRACC (SUBSTRATE)
1001	2	BACKUP POST (10'x10'x8'x8')
1002	2	WOOD BLOCK (10'x10'x8'x8')
1003	2	WOOD BLOCK (10'x10'x8'x8')
1004	2	WOOD BLOCK (10'x10'x8'x8')
1005	2	WOOD BLOCK (10'x10'x8'x8')
1006	2	WOOD BLOCK (10'x10'x8'x8')
1007	2	WOOD BLOCK (10'x10'x8'x8')
1008	2	WOOD BLOCK (10'x10'x8'x8')
1009	2	WOOD BLOCK (10'x10'x8'x8')
1010	2	WOOD BLOCK (10'x10'x8'x8')
1011	2	WOOD BLOCK (10'x10'x8'x8')
1012	2	WOOD BLOCK (10'x10'x8'x8')
1013	2	WOOD BLOCK (10'x10'x8'x8')
1014	2	WOOD BLOCK (10'x10'x8'x8')
1015	2	WOOD BLOCK (10'x10'x8'x8')
1016	2	WOOD BLOCK (10'x10'x8'x8')
1017	2	WOOD BLOCK (10'x10'x8'x8')
1018	2	WOOD BLOCK (10'x10'x8'x8')
1019	2	WOOD BLOCK (10'x10'x8'x8')
1020	2	WOOD BLOCK (10'x10'x8'x8')
1021	2	WOOD BLOCK (10'x10'x8'x8')
1022	2	WOOD BLOCK (10'x10'x8'x8')
1023	2	WOOD BLOCK (10'x10'x8'x8')
1024	2	WOOD BLOCK (10'x10'x8'x8')
1025	2	WOOD BLOCK (10'x10'x8'x8')
1026	2	WOOD BLOCK (10'x10'x8'x8')
1027	2	WOOD BLOCK (10'x10'x8'x8')
1028	2	WOOD BLOCK (10'x10'x8'x8')
1029	2	WOOD BLOCK (10'x10'x8'x8')
1030	2	WOOD BLOCK (10'x10'x8'x8')
1031	2	WOOD BLOCK (10'x10'x8'x8')
1032	2	WOOD BLOCK (10'x10'x8'x8')
1033	2	WOOD BLOCK (10'x10'x8'x8')
1034	2	WOOD BLOCK (10'x10'x8'x8')
1035	2	WOOD BLOCK (10'x10'x8'x8')
1036	2	WOOD BLOCK (10'x10'x8'x8')
1037	2	WOOD BLOCK (10'x10'x8'x8')
1038	2	WOOD BLOCK (10'x10'x8'x8')
1039	2	WOOD BLOCK (10'x10'x8'x8')
1040	2	WOOD BLOCK (10'x10'x8'x8')
1041	2	WOOD BLOCK (10'x10'x8'x8')
1042	2	WOOD BLOCK (10'x10'x8'x8')
1043	2	WOOD BLOCK (10'x10'x8'x8')
1044	2	WOOD BLOCK (10'x10'x8'x8')
1045	2	WOOD BLOCK (10'x10'x8'x8')
1046	2	WOOD BLOCK (10'x10'x8'x8')
1047	2	WOOD BLOCK (10'x10'x8'x8')
1048	2	WOOD BLOCK (10'x10'x8'x8')
1049	2	WOOD BLOCK (10'x10'x8'x8')
1050	2	WOOD BLOCK (10'x10'x8'x8')
1051	2	WOOD BLOCK (10'x10'x8'x8')
1052	2	WOOD BLOCK (10'x10'x8'x8')
1053	2	WOOD BLOCK (10'x10'x8'x8')
1054	2	WOOD BLOCK (10'x10'x8'x8')
1055	2	WOOD BLOCK (10'x10'x8'x8')
1056	2	WOOD BLOCK (10'x10'x8'x8')
1057	2	WOOD BLOCK (10'x10'x8'x8')
1058	2	WOOD BLOCK (10'x10'x8'x8')
1059	2	WOOD BLOCK (10'x10'x8'x8')
1060	2	WOOD BLOCK (10'x10'x8'x8')
1061	2	WOOD BLOCK (10'x10'x8'x8')
1062	2	WOOD BLOCK (10'x10'x8'x8')
1063	2	WOOD BLOCK (10'x10'x8'x8')
1064	2	WOOD BLOCK (10'x10'x8'x8')
1065	2	WOOD BLOCK (10'x10'x8'x8')
1066	2	WOOD BLOCK (10'x10'x8'x8')
1067	2	WOOD BLOCK (10'x10'x8'x8')
1068	2	WOOD BLOCK (10'x10'x8'x8')
1069	2	WOOD BLOCK (10'x10'x8'x8')
1070	2	WOOD BLOCK (10'x10'x8'x8')
1071	2	WOOD BLOCK (10'x10'x8'x8')
1072	2	WOOD BLOCK (10'x10'x8'x8')
1073	2	WOOD BLOCK (10'x10'x8'x8')
1074	2	WOOD BLOCK (10'x10'x8'x8')
1075	2	WOOD BLOCK (10'x10'x8'x8')
1076	2	WOOD BLOCK (10'x10'x8'x8')
1077	2	WOOD BLOCK (10'x10'x8'x8')
1078	2	WOOD BLOCK (10'x10'x8'x8')
1079	2	WOOD BLOCK (10'x10'x8'x8')
1080	2	WOOD BLOCK (10'x10'x8'x8')
1081	2	WOOD BLOCK (10'x10'x8'x8')
1082	2	WOOD BLOCK (10'x10'x8'x8')
1083	2	WOOD BLOCK (10'x10'x8'x8')
1084	2	WOOD BLOCK (10'x10'x8'x8')
1085	2	WOOD BLOCK (10'x10'x8'x8')
1086	2	WOOD BLOCK (10'x10'x8'x8')
1087	2	WOOD BLOCK (10'x10'x8'x8')
1088	2	WOOD BLOCK (10'x10'x8'x8')
1089	2	WOOD BLOCK (10'x10'x8'x8')
1090	2	WOOD BLOCK (10'x10'x8'x8')
1091	2	WOOD BLOCK (10'x10'x8'x8')
1092	2	WOOD BLOCK (10'x10'x8'x8')
1093	2	WOOD BLOCK (10'x10'x8'x8')
1094	2	WOOD BLOCK (10'x10'x8'x8')
1095	2	WOOD BLOCK (10'x10'x8'x8')
1096	2	WOOD BLOCK (10'x10'x8'x8')
1097	2	WOOD BLOCK (10'x10'x8'x8')
1098	2	WOOD BLOCK (10'x10'x8'x8')
1099	2	WOOD BLOCK (10'x10'x8'x8')
1100	2	WOOD BLOCK (10'x10'x8'x8')

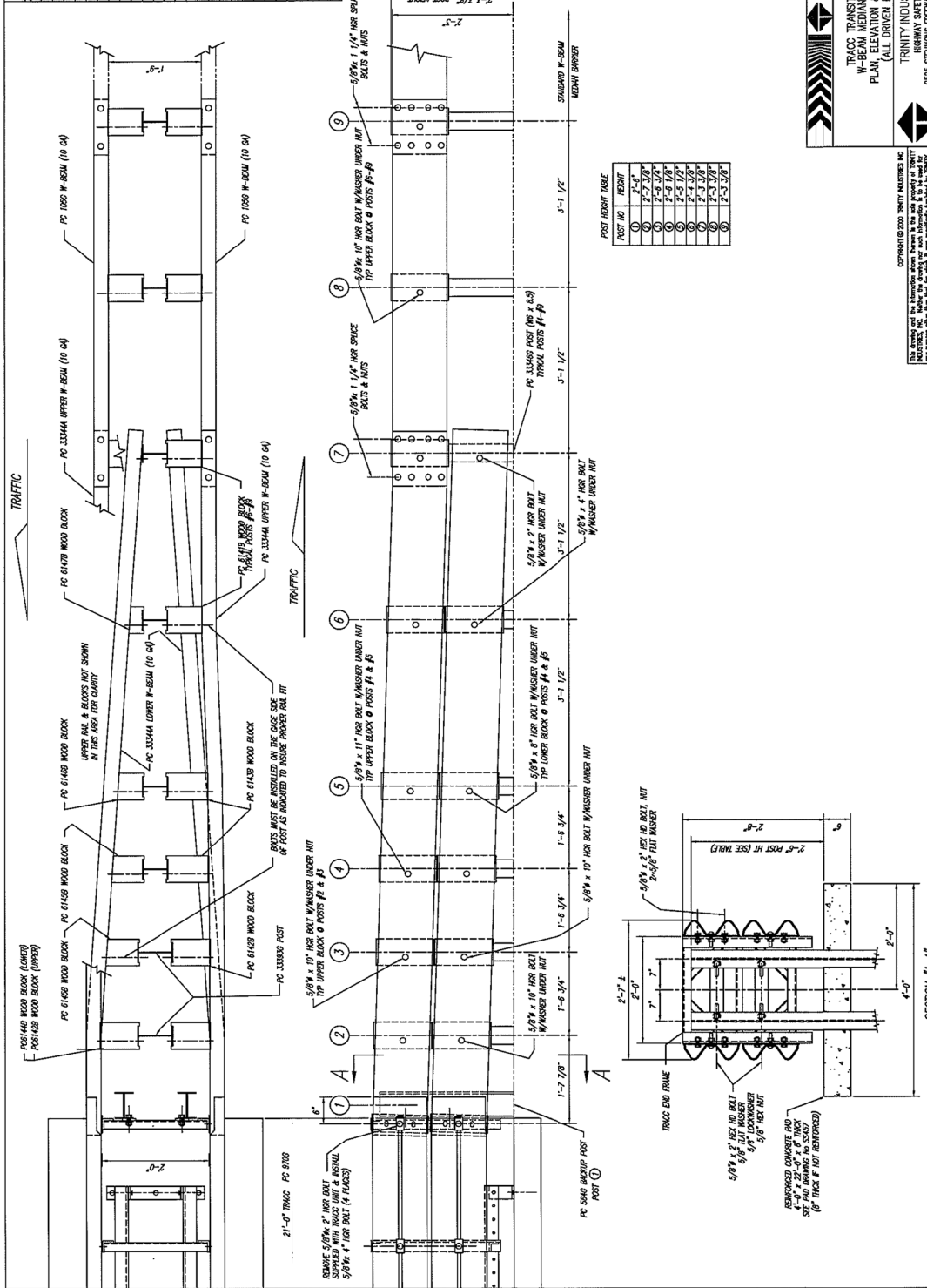

TRACC

TRACC TRANSITION TO W-BEAM MEDIAN BARRIER
 PLAN, ELEVATION & SECTIONS
 (ALL DRIVEN POSTS)

TRINITY INDUSTRIES, INC.
 2025 STANISLAUS FREEWAY, DALLAS, TX 75236

DATE: 8/16/00
 DRAWING NO.: SS 453

ITEM NO.	QTY	DESCRIPTION
33600	2	POST 1/2" x 6.5" x 6'-9"
33601	12	WOOD BLOCK 1'-1" (6" x 3" x 1/4")
33602	3	WOOD BLOCK 1'-1" (6" x 3" x 1/4")
33372A	1	TRAC2/THREE BEAM TRANSITION PANEL
33372A	1	TRAC2/THREE BEAM TRANSITION PANEL
HARDWARE		
33603	4	5/8" x 1/4" HEX BOLT
33604	12	5/8" x 1/4" HEX POST BOLT
33605	24	5/8" x 1/4" x 1 1/4" HRD SPACER BOLT
33606	24	5/8" x 1/4" x 1 1/4" HRD SPACER BOLT
33607	12	1/2" FLAT WASHER (FOR POST BOLTS)
33608	12	1/2" FLAT WASHER (FOR POST BOLTS)
33609	20	5/8" LOCKWASHER
33610	4	5/8" LOCKWASHER
33611	12	5/8" HEX NUT

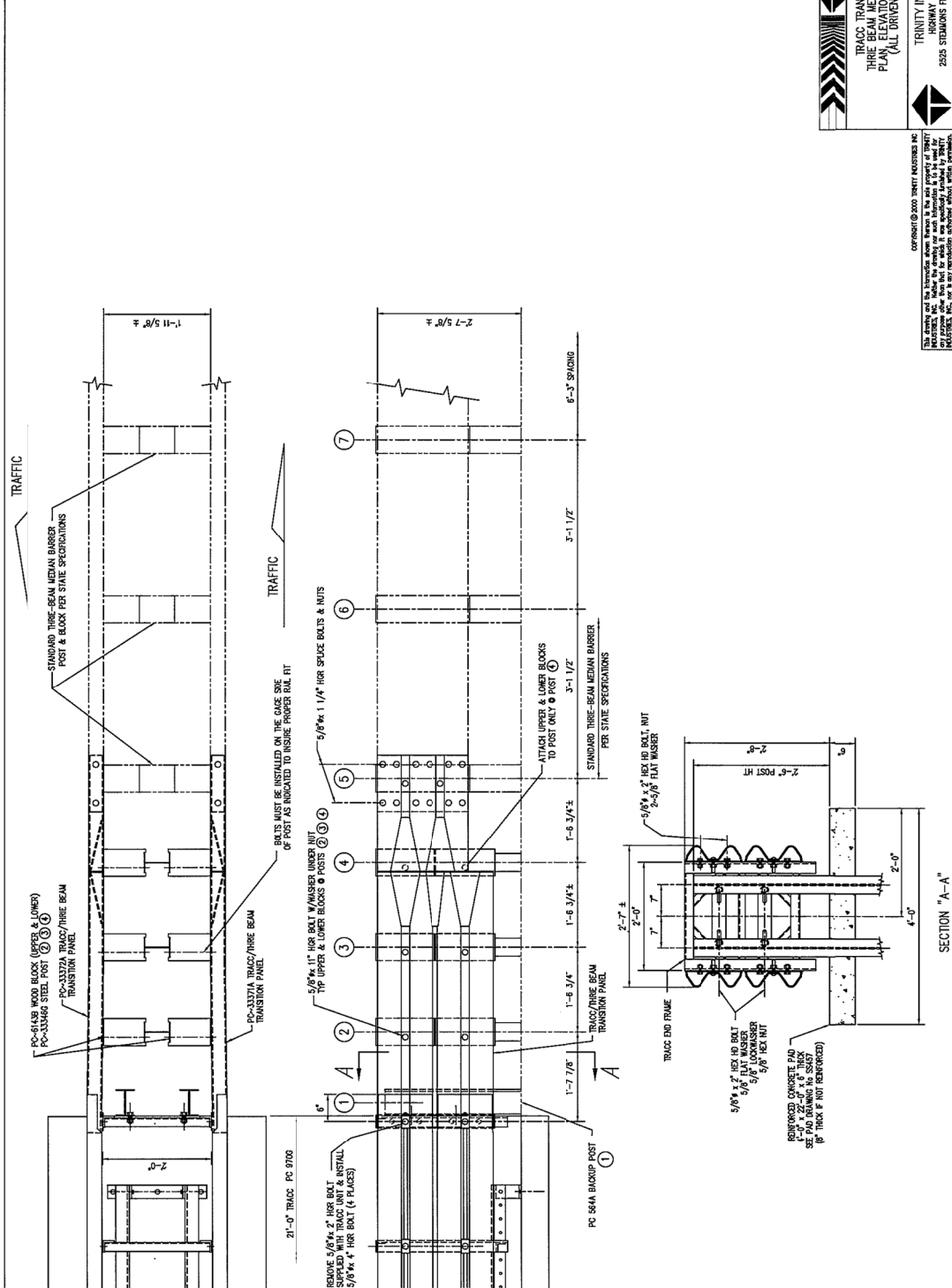

TRACC

TRACC TRANSITION TO THREE BEAM MEDIAN BARRIER PLAN, ELEVATION & SECTIONS (ALL DRIVEN POSTS)

TRINITY INDUSTRIES, INC.
2535 STEWARTS FREEMAN, DALLAS, TX 75238

DATE: 8-22-00
DRAWING NO: SS 454

Copyright © 2000 TRINITY INDUSTRIES, INC. This drawing and the information shown hereon is the sole property of TRINITY INDUSTRIES, INC. and is not to be reproduced, stored in a retrieval system, or transmitted in any form or by any means, electronic, mechanical, photocopying, recording, or by any information storage and retrieval system, without the prior written permission of TRINITY INDUSTRIES, INC.

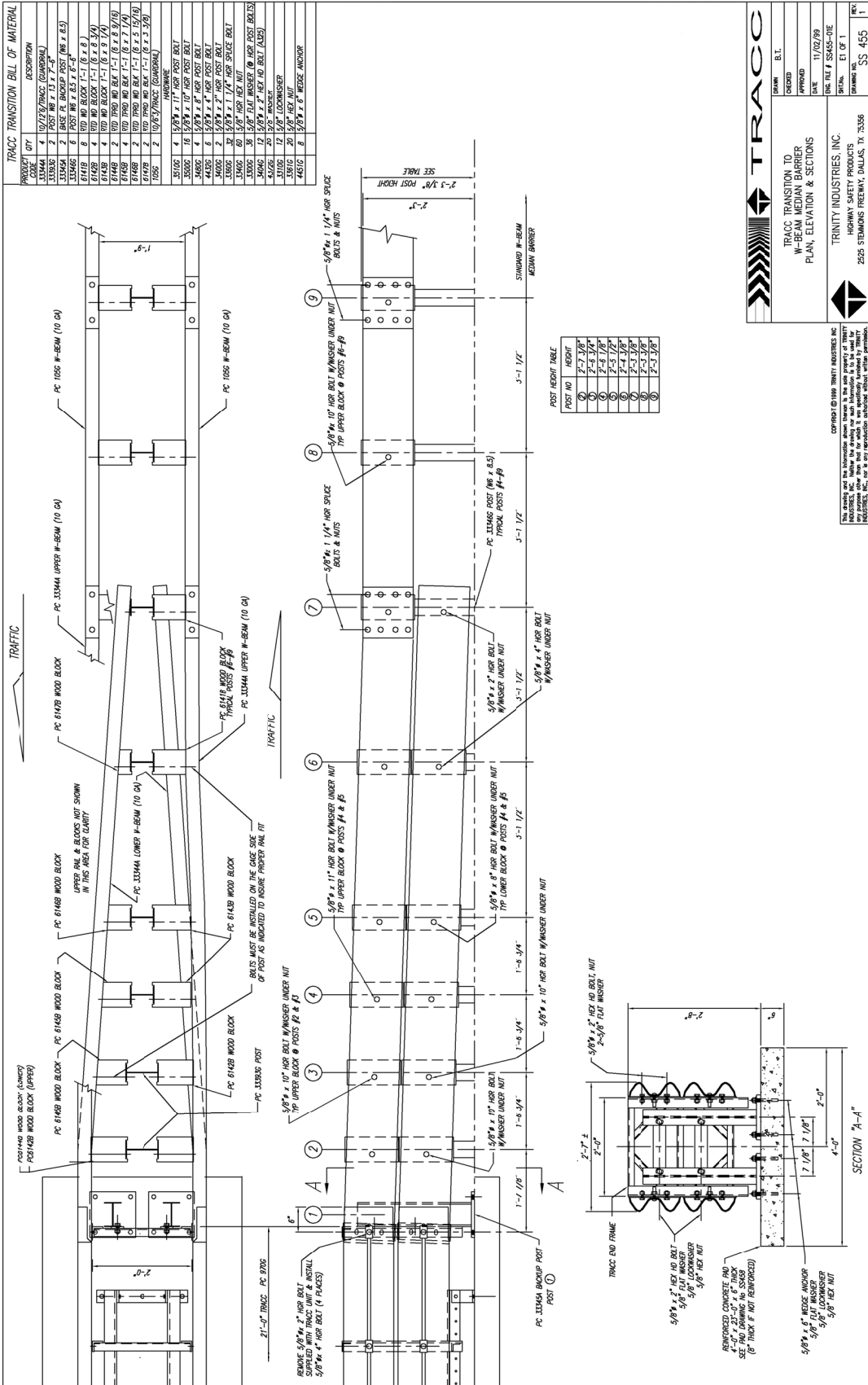

TRACC TRANSITION BILL OF MATERIAL

PROJECT	QTY	DESCRIPTION
13344	4	10/12 TRACC (CHAMFER)
13345	2	POST 1/2\"/>
13346	2	BASE PL. BACKUP POST (1/2\"/>
13347	6	1/2\"/>
13348	4	1/2\"/>
13349	4	1/2\"/>
13350	2	1/2\"/>
13351	2	1/2\"/>
13352	2	1/2\"/>
13353	2	1/2\"/>
13354	2	1/2\"/>
13355	2	1/2\"/>
13356	2	1/2\"/>
13357	2	1/2\"/>
13358	2	1/2\"/>
13359	2	1/2\"/>
13360	2	1/2\"/>
13361	2	1/2\"/>
13362	2	1/2\"/>
13363	2	1/2\"/>
13364	2	1/2\"/>
13365	2	1/2\"/>
13366	2	1/2\"/>
13367	2	1/2\"/>
13368	2	1/2\"/>
13369	2	1/2\"/>
13370	2	1/2\"/>
13371	2	1/2\"/>
13372	2	1/2\"/>
13373	2	1/2\"/>
13374	2	1/2\"/>
13375	2	1/2\"/>
13376	2	1/2\"/>
13377	2	1/2\"/>
13378	2	1/2\"/>
13379	2	1/2\"/>
13380	2	1/2\"/>
13381	2	1/2\"/>
13382	2	1/2\"/>
13383	2	1/2\"/>
13384	2	1/2\"/>
13385	2	1/2\"/>
13386	2	1/2\"/>
13387	2	1/2\"/>
13388	2	1/2\"/>
13389	2	1/2\"/>
13390	2	1/2\"/>
13391	2	1/2\"/>
13392	2	1/2\"/>
13393	2	1/2\"/>
13394	2	1/2\"/>
13395	2	1/2\"/>
13396	2	1/2\"/>
13397	2	1/2\"/>
13398	2	1/2\"/>
13399	2	1/2\"/>
13400	2	1/2\"/>

POST HEIGHT TABLE

POST NO.	HEIGHT
1	2'-3 1/8"
2	2'-3 1/8"
3	2'-5 1/8"
4	2'-5 1/8"
5	2'-5 1/8"
6	2'-4 3/8"
7	2'-3 1/8"
8	2'-3 1/8"
9	2'-3 1/8"

TRACC
 TRACC TRANSITION TO
 W-BEAM MEDIAN BARRIER
 PLAN, ELEVATION & SECTIONS

TRINITY INDUSTRIES, INC.
 HIGHWAY SAFETY PRODUCTS
 2225 STEWARTS FREEWAY, DALLAS, TX 75286

DATE: 11/02/99
 DRAWING NO: TRACC-01E
 SHEET: 1 OF 1
 SCALE: AS SHOWN

TRACC TRANSITION BILL OF MATERIAL	
PROJECT QTY	DESCRIPTION
130870	2 TRACC END END SHOE
	WASERS
41100	4 5/8" LOCKWASHER
44310	4 5/8" x 8 WIDE EDP ANCHOR
68880	8 3/4" x 5 1/2" WIDE EDP ANCHOR

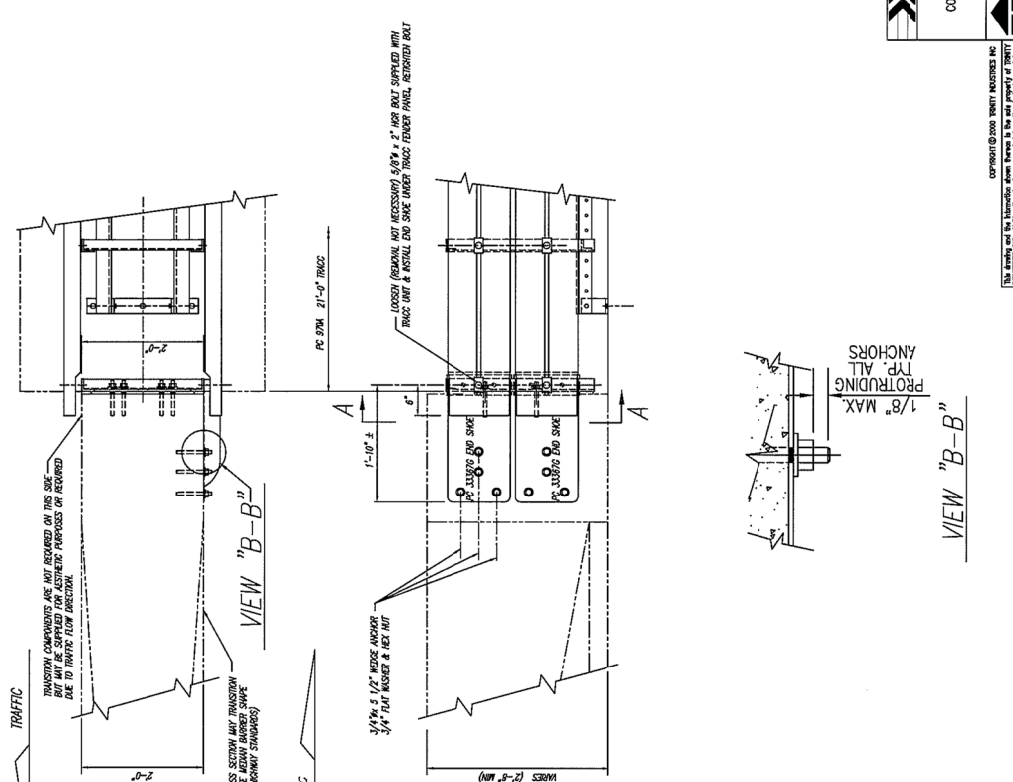

TRACC

TRACC TRANSITION TO VERTICAL CONCRETE WALL, PIER, PARAPET OR BARRIER

PLAN, ELEVATION & SECTIONS

TRINITY INDUSTRIES, INC.
HIGHWAY SAFETY PRODUCTS
2535 STEWARTS FREEWAY, DALLAS, TX 75236

REV. # 1
REV. # 2
REV. # 3
REV. # 4
REV. # 5
REV. # 6
REV. # 7
REV. # 8
REV. # 9
REV. # 10
REV. # 11
REV. # 12
REV. # 13
REV. # 14
REV. # 15
REV. # 16
REV. # 17
REV. # 18
REV. # 19
REV. # 20
REV. # 21
REV. # 22
REV. # 23
REV. # 24
REV. # 25
REV. # 26
REV. # 27
REV. # 28
REV. # 29
REV. # 30
REV. # 31
REV. # 32
REV. # 33
REV. # 34
REV. # 35
REV. # 36
REV. # 37
REV. # 38
REV. # 39
REV. # 40
REV. # 41
REV. # 42
REV. # 43
REV. # 44
REV. # 45
REV. # 46
REV. # 47
REV. # 48
REV. # 49
REV. # 50
REV. # 51
REV. # 52
REV. # 53
REV. # 54
REV. # 55
REV. # 56
REV. # 57
REV. # 58
REV. # 59
REV. # 60
REV. # 61
REV. # 62
REV. # 63
REV. # 64
REV. # 65
REV. # 66
REV. # 67
REV. # 68
REV. # 69
REV. # 70
REV. # 71
REV. # 72
REV. # 73
REV. # 74
REV. # 75
REV. # 76
REV. # 77
REV. # 78
REV. # 79
REV. # 80
REV. # 81
REV. # 82
REV. # 83
REV. # 84
REV. # 85
REV. # 86
REV. # 87
REV. # 88
REV. # 89
REV. # 90
REV. # 91
REV. # 92
REV. # 93
REV. # 94
REV. # 95
REV. # 96
REV. # 97
REV. # 98
REV. # 99
REV. # 100

COMPONENTS AND PARTS IDENTIFIED BY THIS SYMBOL ARE THE PROPERTY OF TRINITY INDUSTRIES, INC. MAKE SURE YOU HAVE THE RIGHT PART FOR YOUR PROJECT. IT IS THE RESPONSIBILITY OF THE USER TO OBTAIN THE RIGHT PART FOR THEIR PROJECT. TRINITY INDUSTRIES, INC. IS NOT RESPONSIBLE FOR ANY DAMAGE TO PROPERTY OR PERSONS RESULTING FROM THE USE OF THESE PRODUCTS.

ITEM	QTY	DESCRIPTION
5300	2	10/2ND SIDE
5309	1	TAPERED HD BOLT 1-1/2" (Ø 1/2" x 1/2")
5310	2	5/8" x 3" UNF. W/SHR. (Ø 1/2" x 1/2")
5311	1	1/2" x 1/2" W/SHR. (Ø 1/2" x 1/2")
5312	1	1/2" x 1/2" W/SHR. (Ø 1/2" x 1/2")
5313	1	1/2" x 1/2" W/SHR. (Ø 1/2" x 1/2")
5314	1	1/2" x 1/2" W/SHR. (Ø 1/2" x 1/2")
5315	1	1/2" x 1/2" W/SHR. (Ø 1/2" x 1/2")
5316	1	1/2" x 1/2" W/SHR. (Ø 1/2" x 1/2")
5317	1	1/2" x 1/2" W/SHR. (Ø 1/2" x 1/2")
5318	1	1/2" x 1/2" W/SHR. (Ø 1/2" x 1/2")
5319	1	1/2" x 1/2" W/SHR. (Ø 1/2" x 1/2")
5320	1	1/2" x 1/2" W/SHR. (Ø 1/2" x 1/2")
5321	1	1/2" x 1/2" W/SHR. (Ø 1/2" x 1/2")
5322	1	1/2" x 1/2" W/SHR. (Ø 1/2" x 1/2")
5323	1	1/2" x 1/2" W/SHR. (Ø 1/2" x 1/2")
5324	1	1/2" x 1/2" W/SHR. (Ø 1/2" x 1/2")
5325	1	1/2" x 1/2" W/SHR. (Ø 1/2" x 1/2")
5326	1	1/2" x 1/2" W/SHR. (Ø 1/2" x 1/2")
5327	1	1/2" x 1/2" W/SHR. (Ø 1/2" x 1/2")
5328	1	1/2" x 1/2" W/SHR. (Ø 1/2" x 1/2")
5329	1	1/2" x 1/2" W/SHR. (Ø 1/2" x 1/2")
5330	1	1/2" x 1/2" W/SHR. (Ø 1/2" x 1/2")
5331	1	1/2" x 1/2" W/SHR. (Ø 1/2" x 1/2")
5332	1	1/2" x 1/2" W/SHR. (Ø 1/2" x 1/2")
5333	1	1/2" x 1/2" W/SHR. (Ø 1/2" x 1/2")
5334	1	1/2" x 1/2" W/SHR. (Ø 1/2" x 1/2")
5335	1	1/2" x 1/2" W/SHR. (Ø 1/2" x 1/2")
5336	1	1/2" x 1/2" W/SHR. (Ø 1/2" x 1/2")
5337	1	1/2" x 1/2" W/SHR. (Ø 1/2" x 1/2")
5338	1	1/2" x 1/2" W/SHR. (Ø 1/2" x 1/2")
5339	1	1/2" x 1/2" W/SHR. (Ø 1/2" x 1/2")
5340	1	1/2" x 1/2" W/SHR. (Ø 1/2" x 1/2")
5341	1	1/2" x 1/2" W/SHR. (Ø 1/2" x 1/2")
5342	1	1/2" x 1/2" W/SHR. (Ø 1/2" x 1/2")
5343	1	1/2" x 1/2" W/SHR. (Ø 1/2" x 1/2")
5344	1	1/2" x 1/2" W/SHR. (Ø 1/2" x 1/2")
5345	1	1/2" x 1/2" W/SHR. (Ø 1/2" x 1/2")
5346	1	1/2" x 1/2" W/SHR. (Ø 1/2" x 1/2")
5347	1	1/2" x 1/2" W/SHR. (Ø 1/2" x 1/2")
5348	1	1/2" x 1/2" W/SHR. (Ø 1/2" x 1/2")
5349	1	1/2" x 1/2" W/SHR. (Ø 1/2" x 1/2")
5350	1	1/2" x 1/2" W/SHR. (Ø 1/2" x 1/2")
5351	1	1/2" x 1/2" W/SHR. (Ø 1/2" x 1/2")
5352	1	1/2" x 1/2" W/SHR. (Ø 1/2" x 1/2")
5353	1	1/2" x 1/2" W/SHR. (Ø 1/2" x 1/2")
5354	1	1/2" x 1/2" W/SHR. (Ø 1/2" x 1/2")
5355	1	1/2" x 1/2" W/SHR. (Ø 1/2" x 1/2")
5356	1	1/2" x 1/2" W/SHR. (Ø 1/2" x 1/2")
5357	1	1/2" x 1/2" W/SHR. (Ø 1/2" x 1/2")
5358	1	1/2" x 1/2" W/SHR. (Ø 1/2" x 1/2")
5359	1	1/2" x 1/2" W/SHR. (Ø 1/2" x 1/2")
5360	1	1/2" x 1/2" W/SHR. (Ø 1/2" x 1/2")
5361	1	1/2" x 1/2" W/SHR. (Ø 1/2" x 1/2")
5362	1	1/2" x 1/2" W/SHR. (Ø 1/2" x 1/2")
5363	1	1/2" x 1/2" W/SHR. (Ø 1/2" x 1/2")
5364	1	1/2" x 1/2" W/SHR. (Ø 1/2" x 1/2")
5365	1	1/2" x 1/2" W/SHR. (Ø 1/2" x 1/2")
5366	1	1/2" x 1/2" W/SHR. (Ø 1/2" x 1/2")
5367	1	1/2" x 1/2" W/SHR. (Ø 1/2" x 1/2")
5368	1	1/2" x 1/2" W/SHR. (Ø 1/2" x 1/2")
5369	1	1/2" x 1/2" W/SHR. (Ø 1/2" x 1/2")
5370	1	1/2" x 1/2" W/SHR. (Ø 1/2" x 1/2")
5371	1	1/2" x 1/2" W/SHR. (Ø 1/2" x 1/2")
5372	1	1/2" x 1/2" W/SHR. (Ø 1/2" x 1/2")
5373	1	1/2" x 1/2" W/SHR. (Ø 1/2" x 1/2")
5374	1	1/2" x 1/2" W/SHR. (Ø 1/2" x 1/2")
5375	1	1/2" x 1/2" W/SHR. (Ø 1/2" x 1/2")
5376	1	1/2" x 1/2" W/SHR. (Ø 1/2" x 1/2")
5377	1	1/2" x 1/2" W/SHR. (Ø 1/2" x 1/2")
5378	1	1/2" x 1/2" W/SHR. (Ø 1/2" x 1/2")
5379	1	1/2" x 1/2" W/SHR. (Ø 1/2" x 1/2")
5380	1	1/2" x 1/2" W/SHR. (Ø 1/2" x 1/2")
5381	1	1/2" x 1/2" W/SHR. (Ø 1/2" x 1/2")
5382	1	1/2" x 1/2" W/SHR. (Ø 1/2" x 1/2")
5383	1	1/2" x 1/2" W/SHR. (Ø 1/2" x 1/2")
5384	1	1/2" x 1/2" W/SHR. (Ø 1/2" x 1/2")
5385	1	1/2" x 1/2" W/SHR. (Ø 1/2" x 1/2")
5386	1	1/2" x 1/2" W/SHR. (Ø 1/2" x 1/2")
5387	1	1/2" x 1/2" W/SHR. (Ø 1/2" x 1/2")
5388	1	1/2" x 1/2" W/SHR. (Ø 1/2" x 1/2")
5389	1	1/2" x 1/2" W/SHR. (Ø 1/2" x 1/2")
5390	1	1/2" x 1/2" W/SHR. (Ø 1/2" x 1/2")
5391	1	1/2" x 1/2" W/SHR. (Ø 1/2" x 1/2")
5392	1	1/2" x 1/2" W/SHR. (Ø 1/2" x 1/2")
5393	1	1/2" x 1/2" W/SHR. (Ø 1/2" x 1/2")
5394	1	1/2" x 1/2" W/SHR. (Ø 1/2" x 1/2")
5395	1	1/2" x 1/2" W/SHR. (Ø 1/2" x 1/2")
5396	1	1/2" x 1/2" W/SHR. (Ø 1/2" x 1/2")
5397	1	1/2" x 1/2" W/SHR. (Ø 1/2" x 1/2")
5398	1	1/2" x 1/2" W/SHR. (Ø 1/2" x 1/2")
5399	1	1/2" x 1/2" W/SHR. (Ø 1/2" x 1/2")
5400	1	1/2" x 1/2" W/SHR. (Ø 1/2" x 1/2")

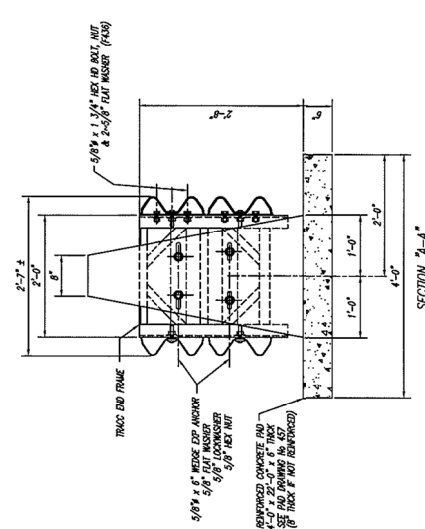
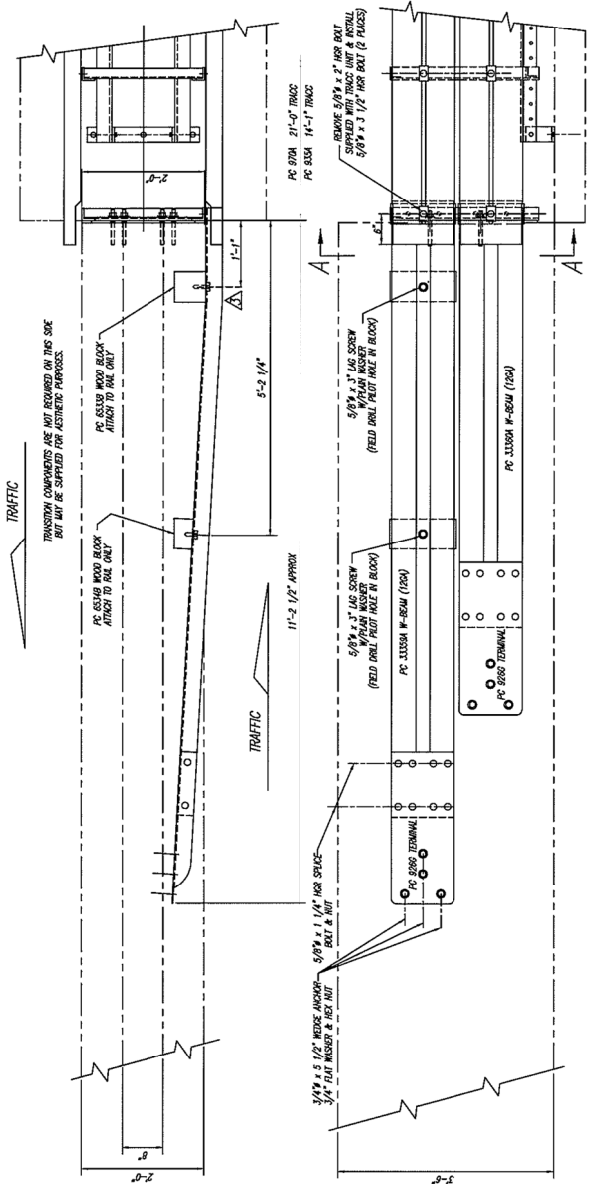

TRACC

TRACC TRANSITION TO CONCRETE CURB ELEVATION & SECTIONS

DATE: 11/05/09

DR: TRACY J. SMITH

PROJECT: E1 OF 1

2525 STEWARTS FREEWAY, DALLAS, TX 75238

35 462

© 1999 TRINITY INDUSTRIES, INC. ALL RIGHTS RESERVED. THIS DRAWING IS THE PROPERTY OF TRINITY INDUSTRIES, INC. AND IS NOT TO BE REPRODUCED OR TRANSMITTED IN ANY FORM OR BY ANY MEANS, ELECTRONIC OR MECHANICAL, INCLUDING PHOTOCOPYING, RECORDING, OR BY ANY INFORMATION STORAGE AND RETRIEVAL SYSTEM. WITHOUT THE WRITTEN PERMISSION OF TRINITY INDUSTRIES, INC.

TRACC TRANSITION BILL OF MATERIAL

ITEM CODE	QTY	DESCRIPTION
33371A	1	TRACC/TIRE BEAM TRANSITION PANEL
33372A	1	TRACC/TIRE BEAM TRANSITION PANEL
33373A	1	TRACC/TIRE BEAM TRANSITION PANEL
33374A	2	BASE PL. BACKUP POST (WB X 3.5)
33346A	5	POST WB X 8.5 X 8'-9"
4439C	1	HARDWARE
33600	12	5/8" X 4" HRR BOLT
33602	12	5/8" X 1 1/4" HRR POST BOLT
33603	24	5/8" X 1 1/4" HRR SPIKE BOLT
33605	36	3/8" HRR HEX NUT
33606	12	3/8" FLAT WASHER (HRR POST BOLT)
4370C	20	5/8" HRR BOLT (AS-10)
33607	12	5/8" LOCKWASHER
33610	12	5/8" HEX NUT
44310	8	5/8" X 5' 6" WEDGE ANCHOR

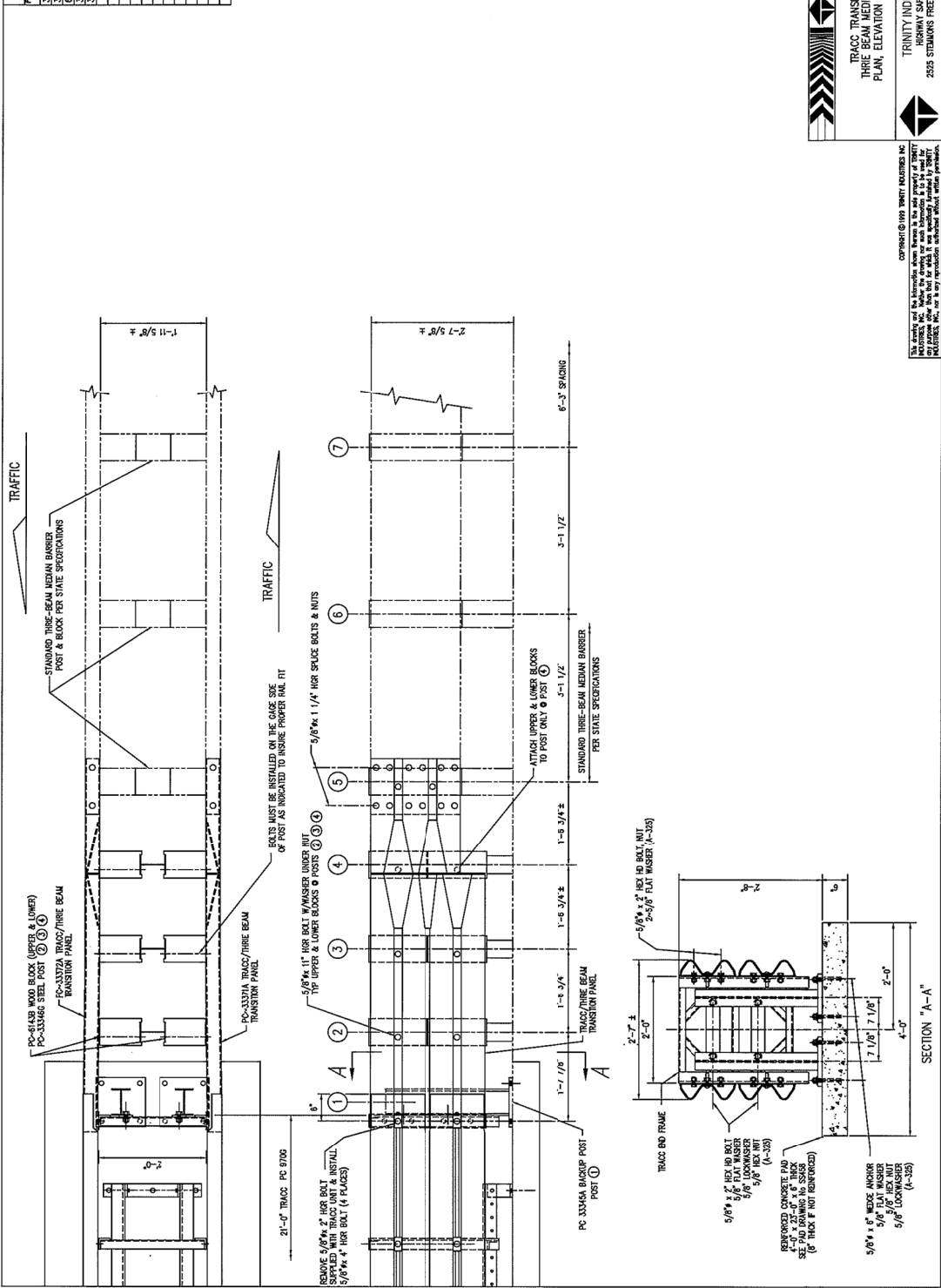

TRACC

TRACC TRANSITION TO THREE BEAM MEDIAN BARRIER PLAN, ELEVATION & SECTIONS

DATE: 11/02/09

DESIGNER: SSK/S-EIE

CHECKER: E1 OF 1

TRINITY INDUSTRIES, INC.

2525 STEWARTS FRESHMAN, DALLAS, TX 75259

SS 463 0

COMPONENT © 1993 TRINITY INDUSTRIES, INC.

This drawing and the information shown herein is the sole property of TRINITY INDUSTRIES, INC. No part of this drawing may be reproduced in any form without the written permission of TRINITY INDUSTRIES, INC. or its representative, whether such reproduction is for any purpose.

TRACC TRANSITION BILL OF MATERIAL	
PROJECT	DESCRIPTION
QTY	
33371A	TRACC/THREE BEAM TRANSITION PANEL
33372A	TRACC/THREE BEAM TRANSITION PANEL
61328	WOOD BLOCK (8" X 8" X 8")
61329	WOOD BLOCK (8" X 8" X 8")
61378	WOOD POST (8" X 8" X 8")
61379	WOOD POST (8" X 8" X 8")
HARDWARE	
44302	5/8" x 2" HEX HD BOLT
38500	5/8" x 2" HEX HD BOLT
38501	5/8" x 2" HEX HD BOLT
33400	5/8" HEX FLAT WASHER
33401	5/8" HEX FLAT WASHER
33402	5/8" FLAT WASHER (FOR POST BACKS)
33403	5/8" FLAT WASHER (FOR POST BACKS)
43700	5/8" WASHER
43701	5/8" WASHER
33410	5/8" HEX NUT
44310	5/8" x 2" WEDGE ANCHOR

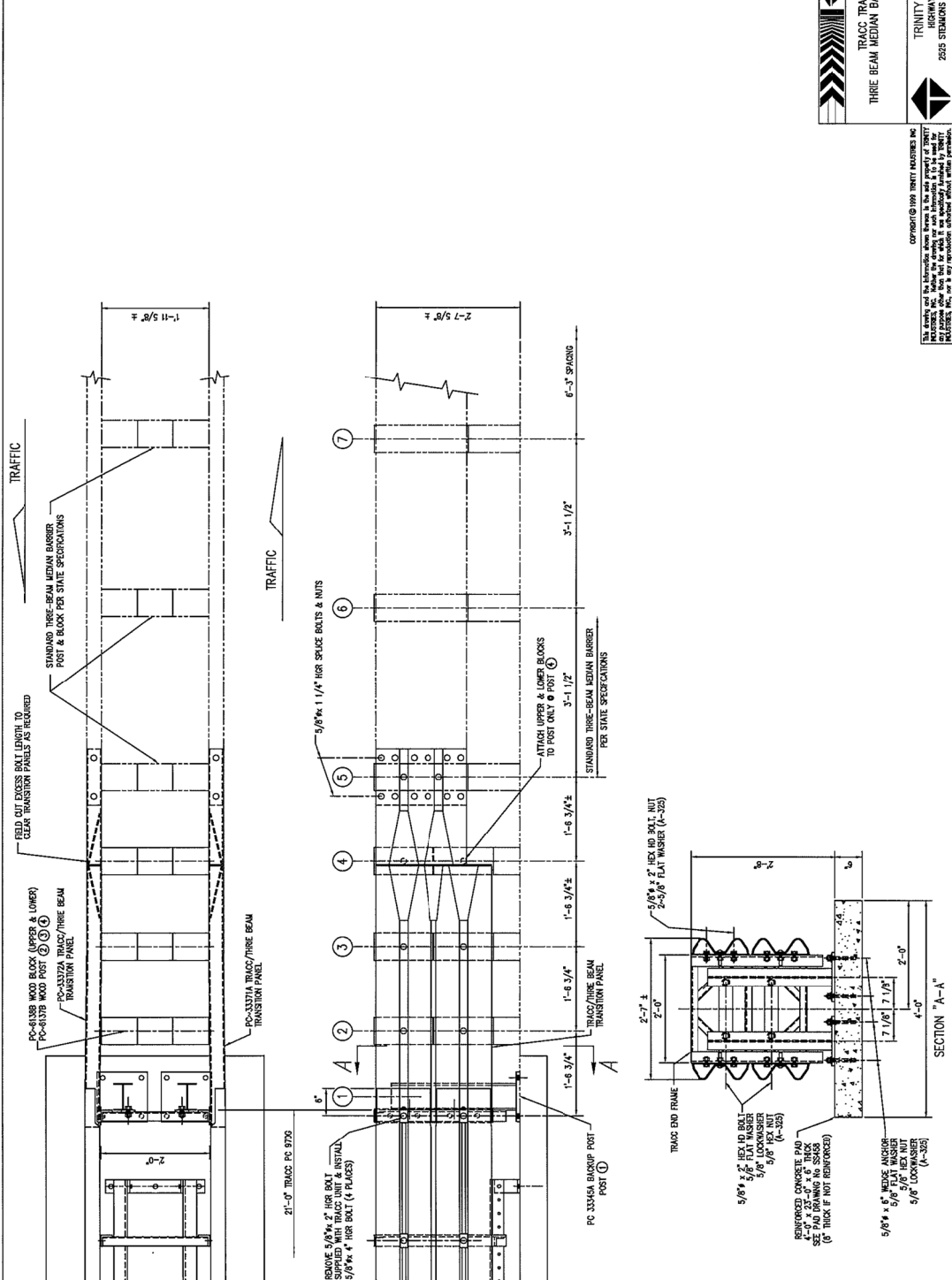

TRACC

TRACC TRANSITION TO
THREE BEAM MEDIAN BARRIER ALL WOOD POST

DATE: 11-2-89
DRAWN BY: SS464-01E
CHECKED BY: E1 OF 1
DATE: 11-2-89
DRAWN BY: SS 464

TRINITY INDUSTRIES, INC.
HIGHWAY SAFETY PRODUCTS
2825 STEWARTS FREDMAN, DALLAS, TX 75228

© 1989 TRINITY INDUSTRIES, INC.
This drawing and the information shown herein is the sole property of TRINITY INDUSTRIES, INC. and shall not be used for any other project without the written permission of TRINITY INDUSTRIES, INC. All rights reserved.

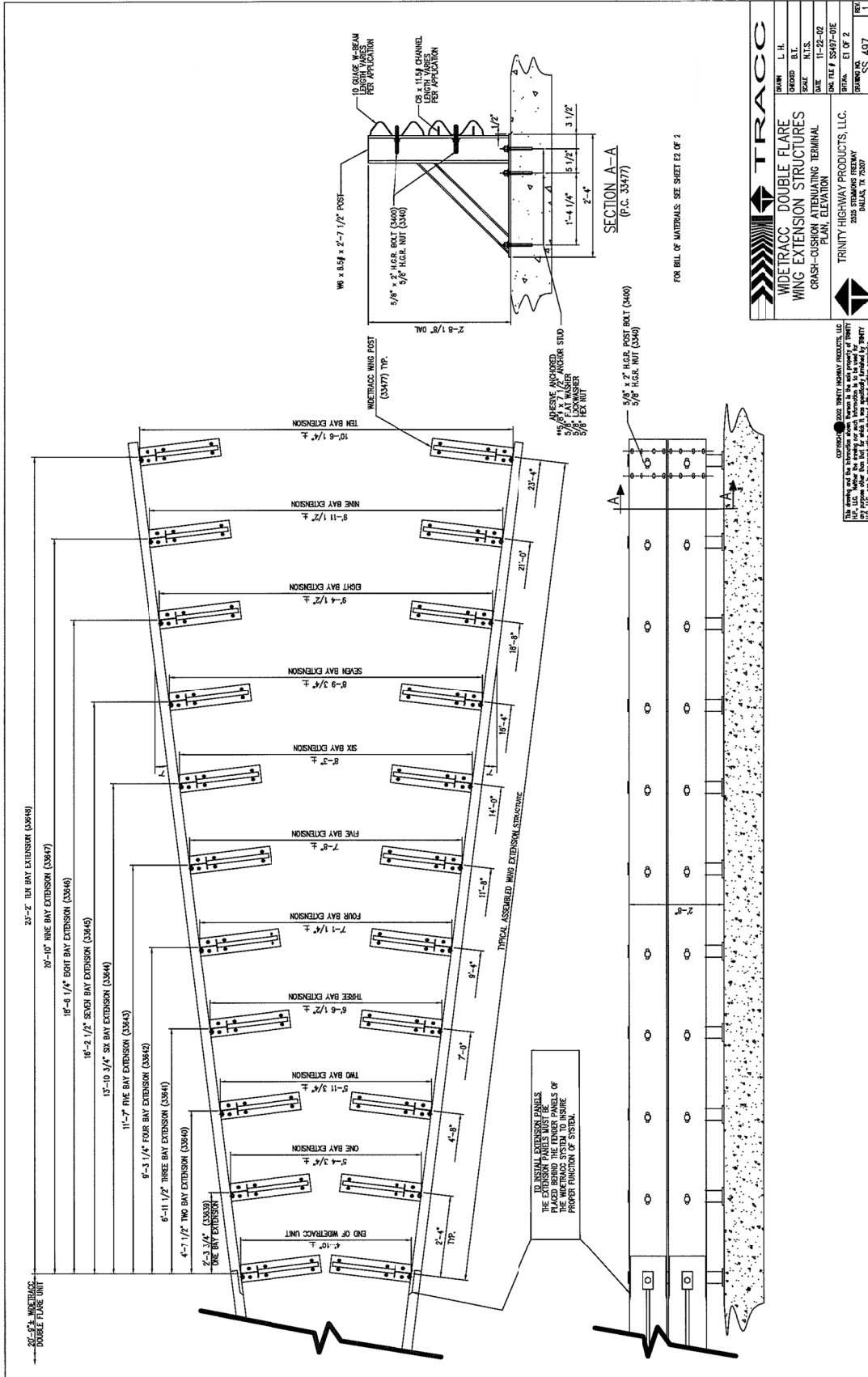

TRACC	
DRAWN	L. H.
DESIGNED	E.T.
SCALE	N.T.S.
DATE	11-22-02
CHK. FILE #	SS487-01E
DRWING NO.	EI OF 2
REV.	SS 487

WIDETRAC DOUBLE FLARE
WING EXTENSION STRUCTURES
CRASH-CUSHION ALTERNATING TERMINAL
PLAN, ELEVATION

TRINITY HIGHWAY PRODUCTS, LLC.
2300 W. UNIVERSITY BLVD.
DALLAS, TX 75207

FOR BILL OF MATERIALS: SEE SHEET E2 OF 2

SECTION A-A
(P.C. 33477)

ADHESIVE ANCHORED
5/8" X 1/2" ANCHOR STUD
5/8" LOCKWASHER
5/8" HEX NUT

5/8" x 2" HIGR. POST BRKT (3400)

WIDETRAC WING POST
(33477) TYP.

2'-9 1/8" OAL

1'-4 1/4"

5 1/2"

3 1/2"

2'-4"

10'-5 1/4" ±

9'-11 1/2" ±

9'-4 1/2" ±

8'-9 3/4" ±

8'-7" ±

7'-8" ±

7'-1 1/4" ±

6'-6 1/2" ±

5'-11 3/4" ±

5'-4 3/4" ±

4'-10" ±

2'-4" TYP.

4'-8"

7'-0"

8'-4"

11'-0"

14'-0"

16'-4"

18'-8"

21'-0"

23'-4"

TYPICAL ASSEMBLED WING EXTENSION STRUCTURE

END OF WIDETRAC UNIT

ONE BAY EXTENSION

TWO BAY EXTENSION

THREE BAY EXTENSION

FOUR BAY EXTENSION

FIVE BAY EXTENSION

SIX BAY EXTENSION

SEVEN BAY EXTENSION

EIGHT BAY EXTENSION

NINE BAY EXTENSION

TEN BAY EXTENSION

22'-3" WIDETRAC DOUBLE FLARE UNIT

23'-2" TEN BAY EXTENSION (33846)

19'-10" NINE BAY EXTENSION (33847)

18'-6 1/4" EIGHT BAY EXTENSION (33848)

16'-2 1/2" SEVEN BAY EXTENSION (33849)

15'-10 3/4" SIX BAY EXTENSION (33844)

15'-7" FIVE BAY EXTENSION (33842)

9'-3 1/4" FOUR BAY EXTENSION (33841)

6'-11 1/2" THREE BAY EXTENSION (33840)

6'-3 1/4" (33839) ONE BAY EXTENSION

TO INSURE PROPER FUNCTION OF THE WIDETRAC SYSTEM, THE PANELS MUST BE INSTALLED IN THE ORDER SHOWN. PLEASE BRUSH THE PANELS OF THE WIDETRAC SYSTEM TO INSURE PROPER FUNCTION OF SYSTEM.

©2002 TRINITY HIGHWAY PRODUCTS, LLC
This drawing and its information shall remain the sole property of TRINITY HIGHWAY PRODUCTS, LLC. No part of this drawing may be reproduced or transmitted in any form or by any means, electronic or mechanical, including photocopying, recording, or by any information storage and retrieval system, without the prior written permission of TRINITY HIGHWAY PRODUCTS, LLC. Use of any reproduction without prior written permission.

TRACC BASE (25981A) BILL OF MATERIALS					
PARTS	DESCRIPTION (REV)	QTY	WT. EACH (LB)	WT. TOTAL	
03391G	5/8" HEAVY HEX HEAD BOLT (A325)	102	0.210	21.42	
04252G	3/8" HEX NUT	2	0.030	0.06	
04353G	1/2" HEX NUT	2	0.070	0.14	
04355G	3/8" 1/2" HEX FLANGE HEAD BOLT (GR.5)	54	0.070	3.78	
25980G	18' BEAM GUIDE	2	180.000	360	
25982A	END SHOE	1	11.000	11	
25982A	Front Anchor Weldment	1	67.000	67	
25952A	Cross Tie	3	18.000	54	
25958G	Rip Plate, Stage 1 (Shipping Plate)	2	0.000	0.00	
25958G	Rip Plate, Stage 2	2	17.000	34	
25958G	Rip Plate, Stage 3	2	17.000	34	
25958G	Rip Plate, Stage 3, Middle	2	20.000	40	
25958G	Rip Plate, Stage 3, Top	2	15.000	30	
25983A	Stage 1 Base Module Assembly	1	211.000	211	
25983A	Stage 2 Base Module Assembly	1	224.000	224	
25983A	Stage 3 Base Module Assembly	1	224.000	224	
00340G	3/8" x 1 1/2" SHOULDER STUD	4	0.060	0.24	
	TOTAL WEIGHT			1483.35	

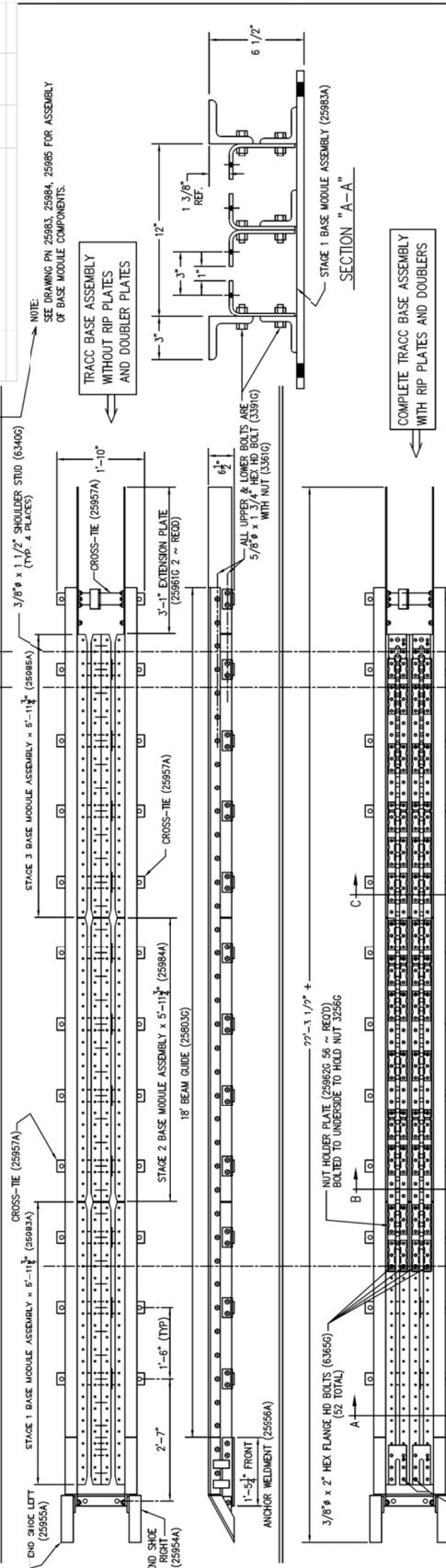

TRACC	
TRACC CRASH-CUSHION ATTENUATING TERMINAL ASSEMBLED BASE UNIT	
PN 25981	
DATE	04/22/05
SCALE	N.T.S.
DRAWN	BT/JH
CHECKED	B.T.
DATE	04/22/05
DATE TRACED	01/28/05
SCALE	E1 OF 1
REV	SS 100/PN 25981 0

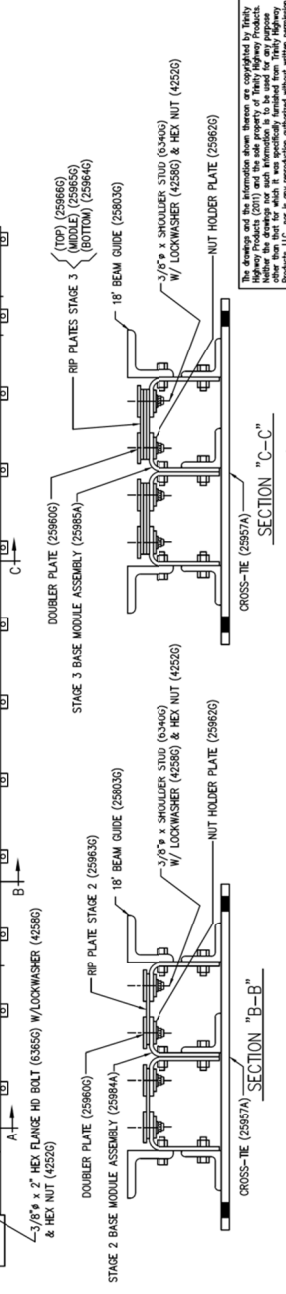

The drawings and the information shown hereon are copyrighted by Trinity Highway Products (2010) and the sole property of Trinity Highway Products. No part of this drawing may be reproduced, stored in a retrieval system, or used for any reproduction authorized without written permission.

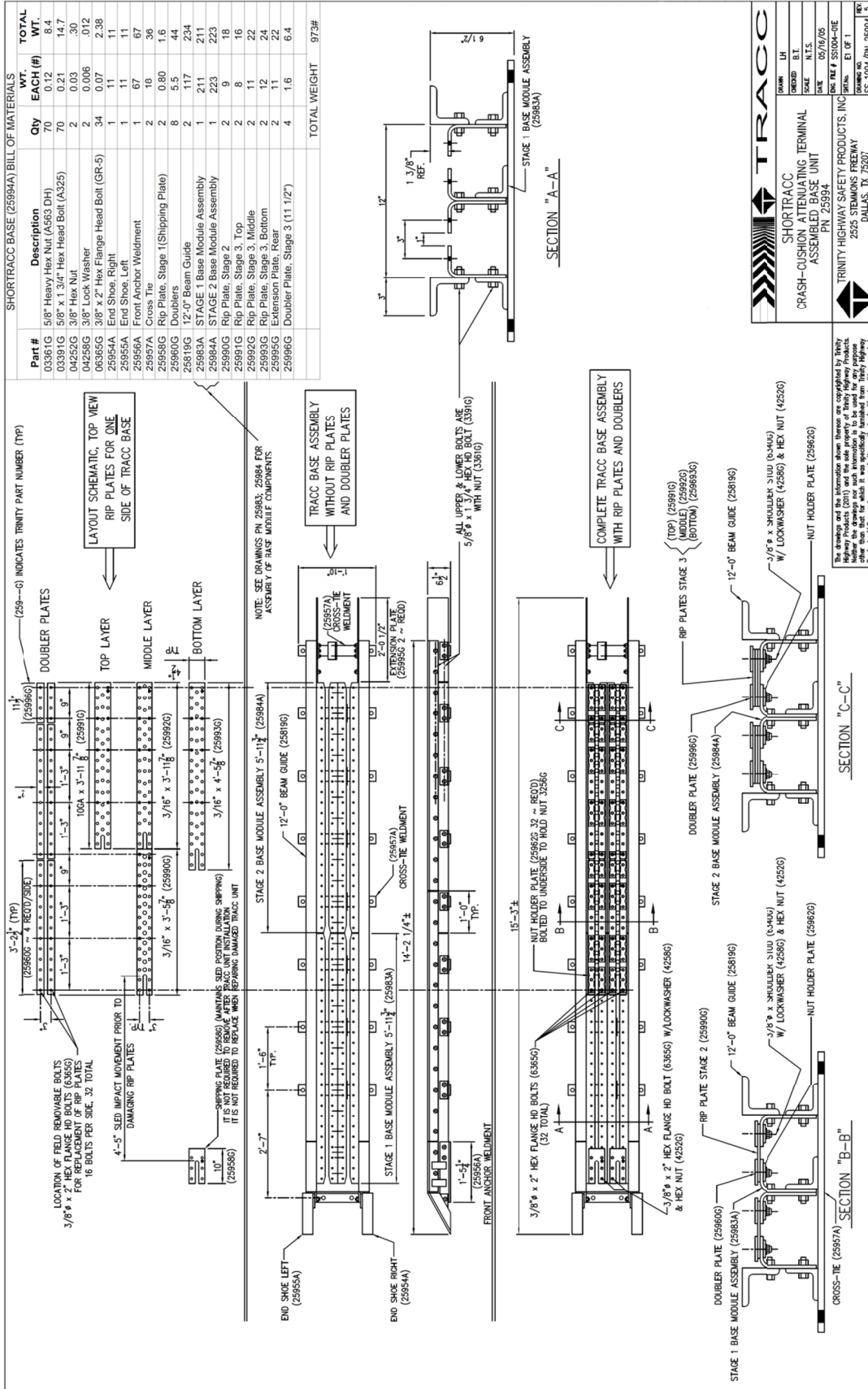

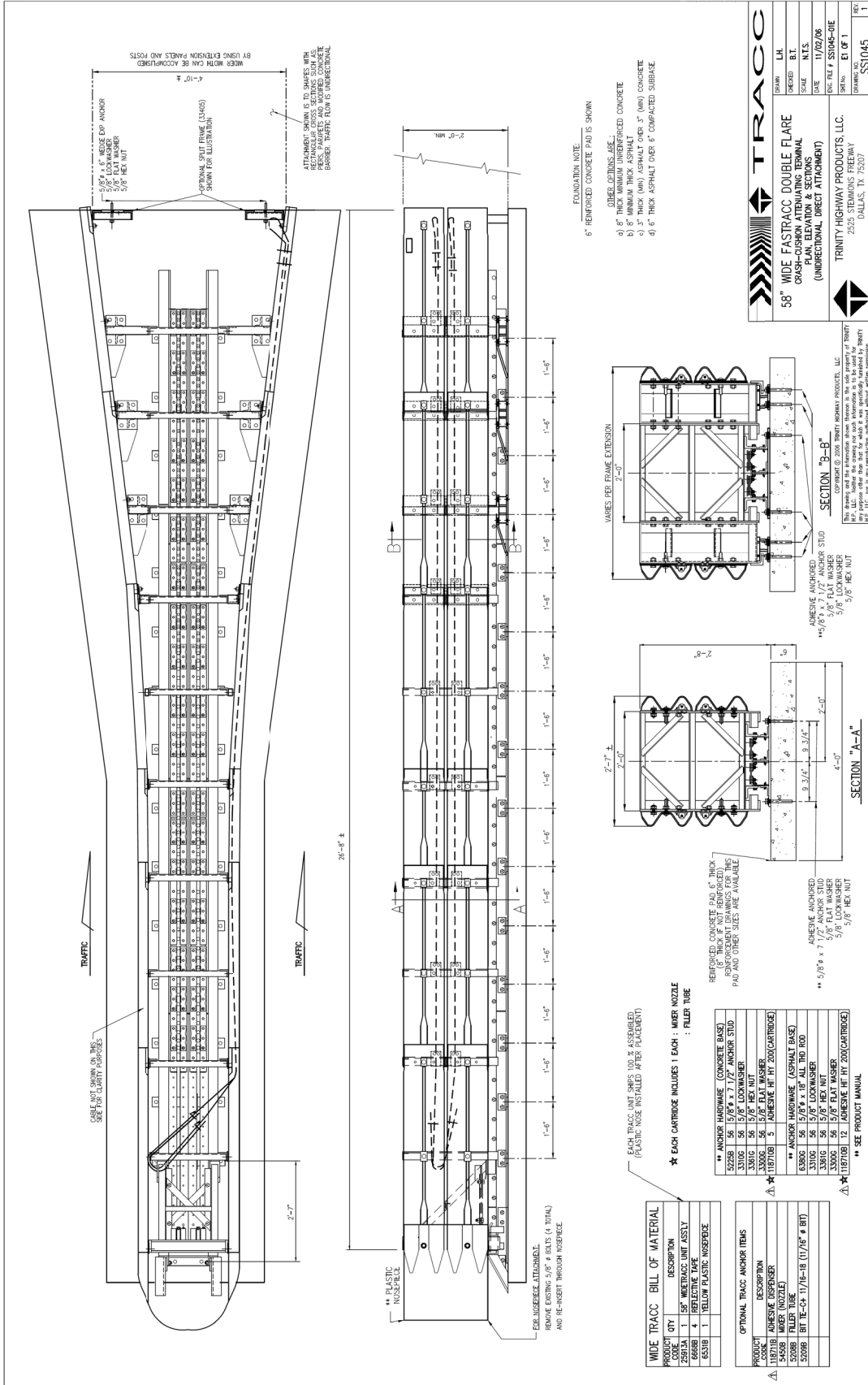

Notes:

Notes:



TRINITY

HIGHWAY

Ahead of the Curve[®]

For more complete information on Trinity Highway products and services, visit us on the web at www.trinityhighway.com. Materials and specifications are subject to change without notice. Please contact Trinity Highway to confirm that you are referring to the most current instructions.

www.trinityhighway.com

888.323.6374 (USA)

+1 214.589.8140 (International)